



# Plymouth Historic District Commission Meeting Agenda

Thursday, January 9, 2020 – 7:00 p.m.

Plymouth City Hall Commission Chambers

City of Plymouth  
201 S. Main  
Plymouth, Michigan 48170

[www.plymouthmi.gov](http://www.plymouthmi.gov)  
Phone 734-453-1234  
Fax 734-455-1892

- 1) **CALL TO ORDER**
- 2) **CITIZENS COMMENTS**
- 3) **APPROVAL OF THE MINUTES**
  - a) Approval of the December 4, 2019, Regular Meeting Minutes
- 4) **APPROVAL OF THE AGENDA**
- 5) **ELECTION OF OFFICERS**
- 6) **COMMISSION COMMENTS**
- 7) **OLD BUSINESS**
  - a) H19-10: Rear Porch at 260 S. Union.
  - b) H19-06: New construction at 686 Maple and 674 Maple. Landscaping, paving, and exterior modifications at 587 W. Ann Arbor Trail.
- 8) **NEW BUSINESS**
  - a) H20-01: Sculpture at 381 S. Main, Kellogg Park (Triangle area at/near S. Union and Ann Arbor Tr.)
- 9) **REPORTS AND CORRESPONDENCE**
- 10) **ADJOURNMENT**

*Citizen Comments - This section of the agenda allows up to 3 minutes to present information or raise issues regarding items not on the agenda. Upon arising to address the Commission, speakers should first identify themselves by clearly stating their name and address. Comments must be limited to the subject of the item.*

*Persons with disabilities needing assistance with this should contact the City Clerk's office at 734-453-1234 Monday through Friday from 8:00 a.m. -4:30 p.m., at least 24 hours prior to the meeting. An attempt will be made to make reasonable accommodations.*

# City of Plymouth Strategic Plan 2017-2022

## GOAL I - QUALITY OF LIFE

### OBJECTIVES

1. Support the neighborhoods with high-quality customer service
2. Engage in collaboration with private entities and surrounding municipalities to implement the Joint Recreation Master Plan
3. Improve communication with the public across multiple platforms
4. Maintain a high level of cleanliness throughout the City
5. Support and host a diverse variety of events that foster community and placemaking

### ONE YEAR TASKS 2019-2020

- Restore operations for recreation programs after Hines Park bridge repairs are completed
- Explore funding and partnership opportunities to increase and enhance pedestrian crossings
- Finalize City website update
- Develop and adopt a Master Plan for Kellogg Park, including the fountain
- Develop and implement strategy to market sponsorship opportunities to improve publicly owned assets
- Draft and approve amendments to Tree Ordinance to clarify implementation, enforcement, and scope

## GOAL II - FINANCIAL STABILITY

### OBJECTIVES

1. Approve balanced budgets that maintain fiscal responsibility
2. Advocate for increased revenue sharing with the State of Michigan
3. Encourage and engage in partnerships, both public and private, to share costs of services and equipment
4. Address the issue of legacy costs
5. Seek out and implement efficient and effective inter-departmental collaboration
6. Market our successes to attract new economic and investment opportunities

### ONE YEAR TASKS 2019-2020

- Continue to support Michigan Municipal League (MML) efforts to coordinate state initiatives related to revenue sharing with municipalities
- Increase awareness of and support the MML Save MI City campaign
- Target revenue enhancements that support large capital projects, including grants and millages
- Explore internal and external potential for supplemental funding of legacy costs
- Develop a plan for capital improvement funding projects and purchases
- Explore enhanced investment opportunities

## GOAL III - ECONOMIC VITALITY

### OBJECTIVES

1. Continue to support and improve active, vibrant downtown branding
2. Support community and economic development projects and initiatives
3. Support a mix of industrial, commercial and residential development
4. Reference the Master Plan in economic decision-making

### ONE YEAR TASKS 2019-2020

- Complete and approve the DDA Master Plan
- Address and implement recommendations in the Redevelopment Ready Communities baseline report
- Develop and approve city-wide economic development strategies (Saxton's property, parking system, connections between Old Village and the DDA, Bathey property remediation and development, 240 N. Main, Lumber Mart site)
- Identify other properties of significance to the economic development strategy
- Complete a community survey
- Increase collaborations with partners in the community
- Administer the City's Master Plan using implementation matrix (Appendix Table 5)

## GOAL IV - SERVICE AND INFRASTRUCTURE

### OBJECTIVES

1. Support administration and staff by providing professional development opportunities, supplying resources, and maintaining a commitment to recruitment, retention and succession planning
2. Support and deliver safe and responsive emergency services
3. Maintain a sophisticated and responsive technology to communicate and manage data
4. Continually record, maintain, update, and improve City infrastructure

### ONE YEAR TASKS 2019-2020

- Begin implementation of parking recommendations for City parking system
- Develop and utilize consistent message and branding across all platforms
- Develop and approve of plan for future delivery of emergency services
- Implement infrastructure asset management plan
- Approve agreement on sanitary sewer with Western Township Utilities Authority (WTUA)

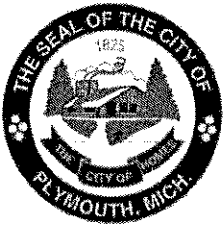

**Plymouth Historic Distric Commission**  
**Meeting Minutes**  
**Wednesday, December 4, 2019 – 7:00p.m.**  
**Plymouth City Hall Commission Chambers**

---

City of Plymouth  
201 South Main Street  
Plymouth, Michigan 48170

[www.plymouthmi.gov](http://www.plymouthmi.gov)  
Phone 734-453-1234  
Fax 734-455-1892

**1. CALL TO ORDER**

Chair Polin called the meeting to order at 7:01 p.m.

PRESENT: Linda Filipczak, Linda May, Joshua Mrozowski, John Townsend, and Colleen Polin

ABESENT: Jeremy Borys & Stanley Cole

Also present was Community Development Director, John Buzuvis and City Commission Liaison, Suzi Deal.

**2. CITIZEN COMMENTS**

None.

**3. APPROVAL OF THE MEETING MINUTES**

a) A motion was made by Comm. Townsend and seconded by Comm. May to approve the meeting minutes from November 6, 2019 as amended.

MOTION PASSED 5-0

**4. APPROVAL OF THE AGENDA**

A motion was made by Comm. Filipczak and seconded by Comm. May to approve the agenda as presented.

MOTION PASSED 5-0

**5. COMMISSIONER COMMENTS**

Chair Polin thanked Mr. Bake for his part in the making of the Plymouth documentary "A Rich History" produced by, Mark Salloum.

Mr. Bake thanked Chair Polin for the kind remarks.

**6. OLD BUSINESS**

None.

**7. NEW BUSINESS**

a). H19-10: Rear Porch at 260 S. Union

Bob Bake, owner explained the materials proposed for the rear porch. The applicant proposes replacement of the newel posts and ballustrates on the rear porch and explained the deterioration over the years. The applicant proposes to use a composite material, he explained to withstand the weather elements and presented photos to the board. He then explained his goal was to repair the damaged wood it will require removing the entire railing system and replacement with the composite materials. The applicant also indicated to the board that he intends to replace the roof shingles and asked for that approval from the board as well. The applicant indicated the new shingles would match the existing shingles exactly and he has a sample in his vehicle.

## **Board Discussion**

Comm. Townsend spoke about the applicant's synopsis asking to only replace the damaged wood and asked for clarification on the proposed work. The applicant answered he intended to replace the entire railing system and porch components with a composite material. Comm. Townsend asked if the composite would match the existing and the applicant responded it would be 95% there. Comm. Townsend asked the applicant if he has had the wood looked at by an expert to determine that it would in fact need to be replaced rather than being repaired and the applicant indicated he had and that the primary components were damaged beyond repair and could not be worked into the new product proposed.

Comm. Filipczak asked about the proposed railings and posts not matching the existing and the applicant responded that he could not obtain a photo of the square ballastrate he would be using. Chair Polin explained that there are 39 historic properties within the Cities historic district and spoke about the Secretary of Interior standards regarding repairs being like for like are allowed and do not require HDC approvals. Chair Polin felt the original submittal and what the applicant is now proposing are different and a detailed materials list, samples and other required information was not included with the application packet.

Comm. Mrozowski asked the applicant what exactly is being proposed, are the replacements proposed different from what is existing? The applicant explained the handrails are an exact replacement, the balusters will be square. He asked the board to look beyond the lack of a detailed drawing with dimensions. Comm. Mrozowski asked if the replacements would be also made of wood and the applicant stated they would be made of a plastic composite material.

Chair Polin asked if the roof replacement would be like for like and the applicant responded yes, it was.

John Buzuvis explained to the applicant that he would need to pull a building permit for the roof replacement and as long as the replacement materials match the existing exactly HDC approval would not be required.

Comm. Townsend was concerned about not receiving actual samples and asked the applicant to provide them. The applicant suggested the board request a \$2500 bond to ensure compliance.

Chair Polin explained to the applicant, part of the application is to look at the materials presented. It is not just about the aesthetics the board also looks at the content, quality and how the materials match with the detailed information. There is a set of standards in place that is applied to every applicant, having a complete application assists us to in making informed decisions.

There was discussion on possible motions and the applicant's missing information needed for re-submission.

The applicant withdrew his application.

## **8. REPORTS AND CORRESPONDENCE**

Mr. Buzuvis spoke about the January 2020 meeting. Mr. Buzuvis explained the actual meeting date falls on the first of January and the need to change it to an alternate date.

It was decided to change the meeting date in January to Thursday, January 9<sup>th</sup> @ 7PM.

City Commission Liaison, Suzi Deal thanked the board for their work and consistency with each applicant, she appreciated their commitment to the Historic District board.

Chair Polin thanked the board also and wished them a very Merry Christmas and holiday.

## **9. ADJOURNMENT**

A motion was made by Comm. Townsend, supported by Comm. May, to adjourn the meeting at 7:58 p.m.

MOTION PASSED 5-0

J19

# COLONNADE

Porch posts provide the industry's easiest installation.

Rated at 5,400# load-bearing capacity.

*this* →

## Size

5" x 5" x 108"

## Colors



Polar White



White



Tan



Clay

*not this* ↓

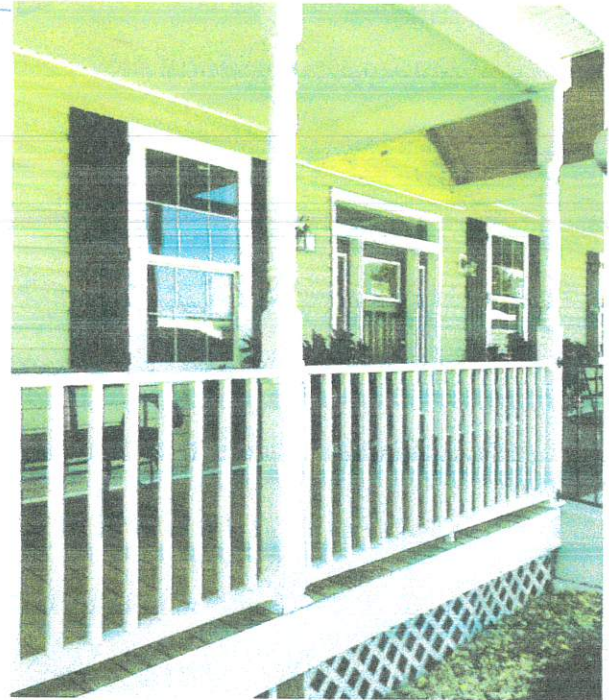

DEC 16 2019

H19-10

260 S. Union  
Rear Porch Repair  
HD Mtg 1/9/20

# 260 S. Union Baluster Spacing and Dimensions

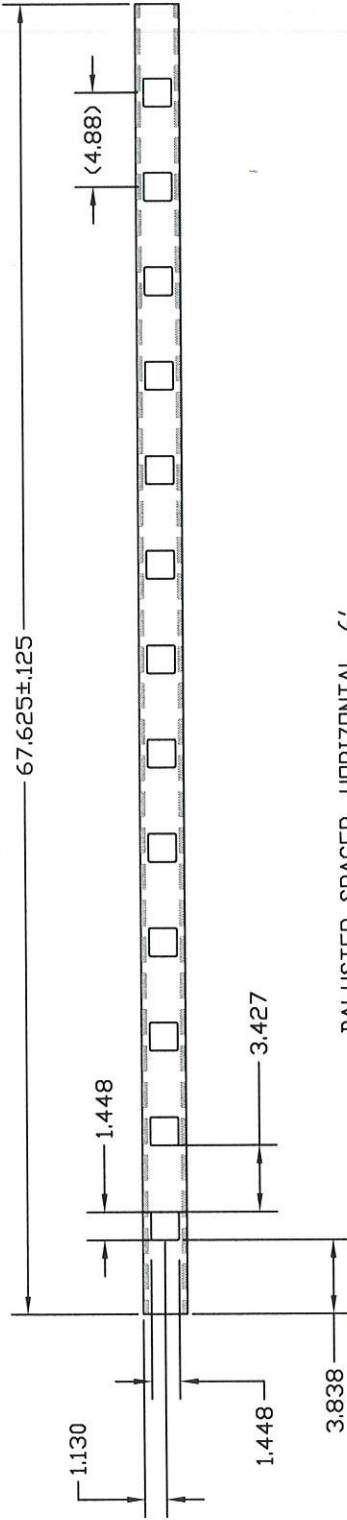

BALUSTER SPACER, HORIZONTAL, 6'

Top Square Baluster 1.448 inches

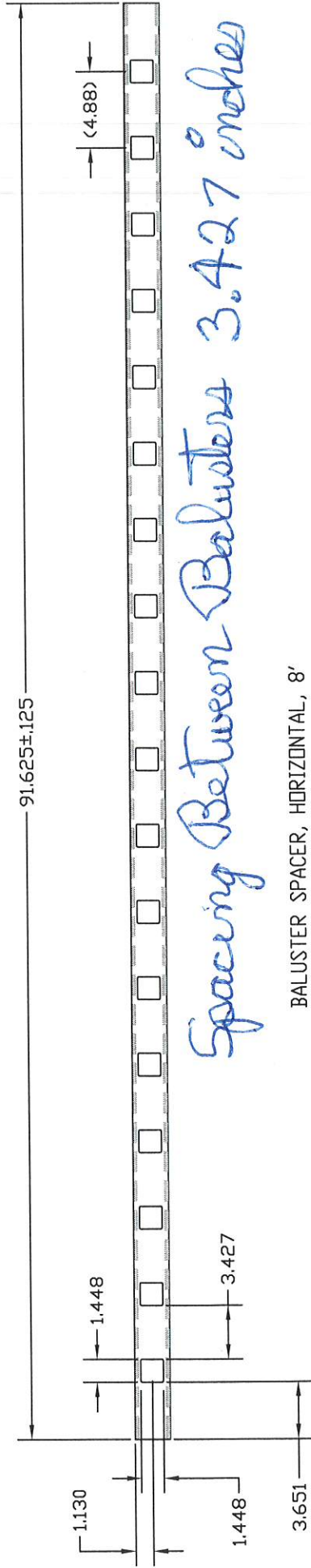

BALUSTER SPACER, HORIZONTAL, 8'

Spacing Between Balusters 3.427 inches

DEC 12 2019

# APPLICATION FOR DETERMINATION OF APPROPRIATENESS

Please consult the following submittal checklist to ensure you submit a complete application and supporting information about the type of work proposed.

Property Location (Address of Work): 260 S. Union

Contributing Structure     Non-Contributing Structure

NOV 18 2019

Building Owner: BOB BAKE

Building Owner Address: 1303 PARK PLACE, PLYMOUTH

Phone: 734 649 2175      Email: harborbobbahe@gmail.com

Applicant: BOB BAKE

Phone: same as above      Email: same as above

Applicant's Role:  Building Owner     Architect     Contractor     Other

## TYPE OF WORK PROPOSED (Check all that apply):

- |   |  |  |
|---|--|--|
| <input type="checkbox"/> New Construction   | <input type="checkbox"/> Sign / Awning Install / Replacement | <input checked="" type="checkbox"/> <sup>REAR</sup> Porch <i>rearing replacement</i> |
| <input type="checkbox"/> Addition           | <input type="checkbox"/> Fence Install / Replacement         | <input checked="" type="checkbox"/> <del>Reconstruction/Repair</del>                 |
| <input type="checkbox"/> Alteration         | <input type="checkbox"/> Paving Install / Replacement        | <input type="checkbox"/> Paint Color Change  |
| <input type="checkbox"/> Window Replacement | <input type="checkbox"/> Wall Install / Replacement          | <input type="checkbox"/> Building Cleaning   |
| <input type="checkbox"/> Door Replacement   | <input type="checkbox"/> Landscaping Install / Replacement   | <input type="checkbox"/> Other   |
| <input type="checkbox"/> Roof Replacement   |  |  |
| <input type="checkbox"/> Siding Replacement |  |  |

**Application Deadline:** The Historic District Commission typically meets the first Wednesday of each month. Please confirm meeting date as meeting schedules may change due to holidays or other unforeseen circumstances. Application material must be completed and submitted to the Community Development Department by 3:00PM on the third Monday of the previous month in order to be placed on the agenda for the following month's meeting. Please check the city's website for exact submission deadlines.

## PLEASE PROVIDE TEN (10) COPIES OF ALL SUBMITTALS

Submittal must include index of sheets (what is included) and all sheets must be numbered and dated.

Robert W. Bake      11-17-19  
Applicant's Signature      Date

I, as the Building Owner, confirm with my signature below that I am aware of and approve the work proposed.

Robert W. Bake      11-17-19  
Building Owner's Signature      Date

H19-10    260 S. Union  
Rear Porch Repair  
HD Mtg 12/4/19

---

1. Synopsis: description of the project in words.

This work is to replace only the weathered/damaged wood balusters and/or portion of handrails on an open-air porch on the west elevation of 260 S. Union. This is a replacement of porch components approved by the HDC in 1994 and installed in 1994. The open-air porch was added in 1994 and functions as an entrance for owners or employees only. This replacement of railing components is minor in nature and as stated in my email of October 30<sup>th</sup> is proposed to be composite mirroring the existing 1994 HDC approved renovation of the structure. The proposed replacement will go unnoticed by the public.

2. Detailed justification of why item needs to be replaced:

An up-close physical viewing would confirm the minor nature of the work proposed and the deterioration of the existing wood railing system.

11-18-2019

IMG\_0741.JPG

11/18/2019

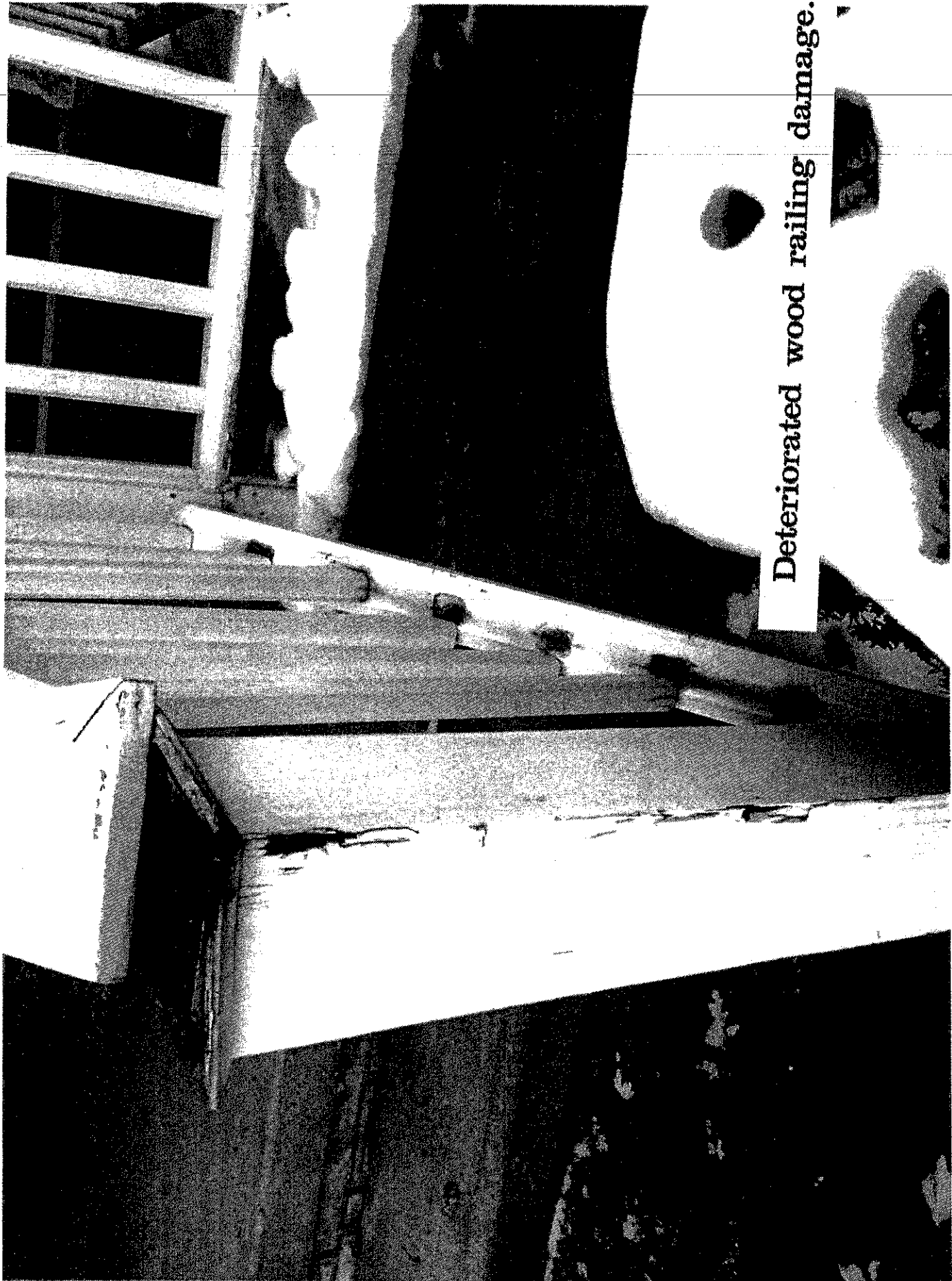

Deteriorated wood railing damage.

11-18-2019

IMG\_0743.JPG

11/18/2019



Western porch elevation.

11-18-2011

1988 260 S Union west elevation

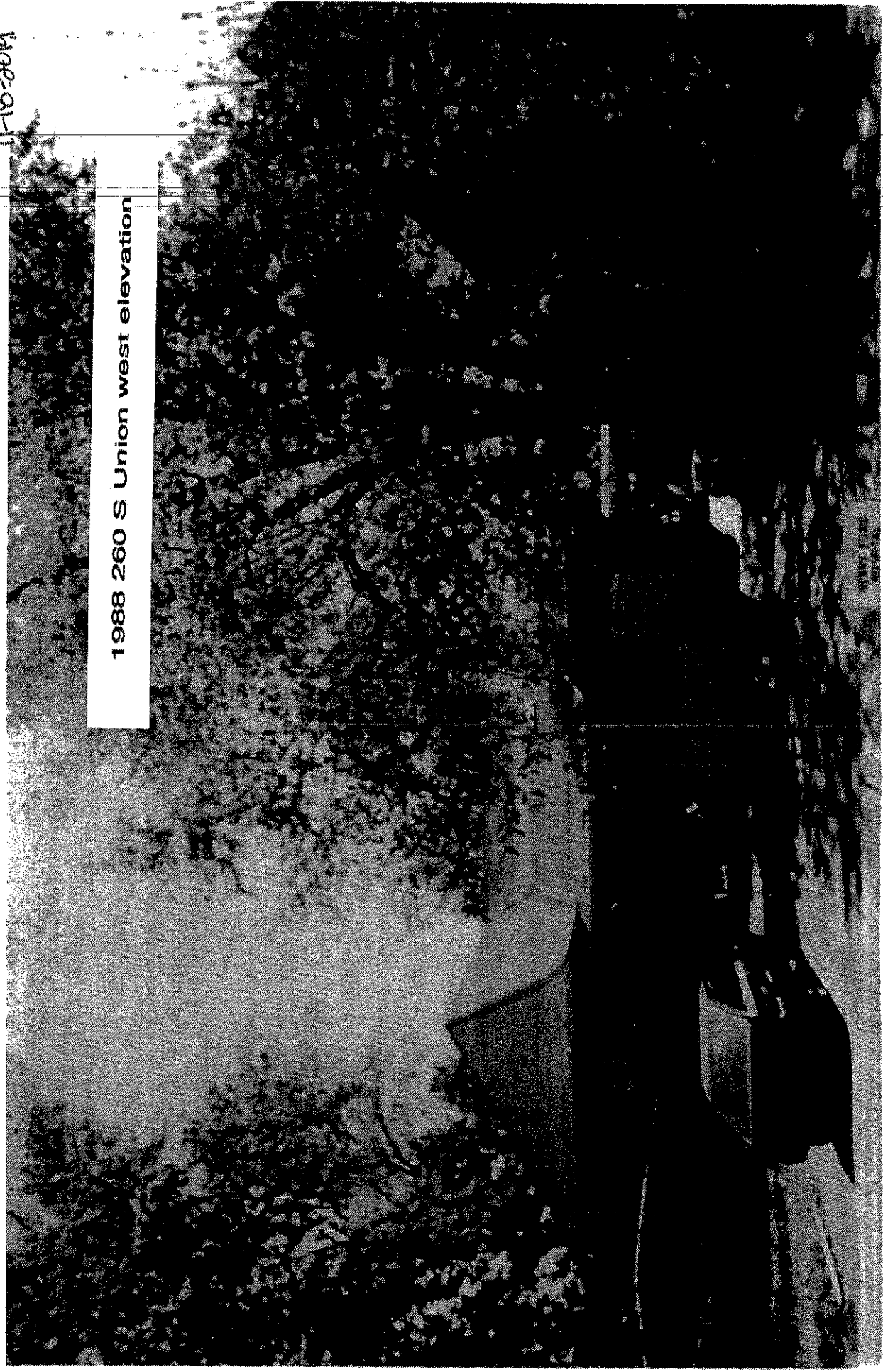

11-18-2019

21

1994 260 S Union west elevation

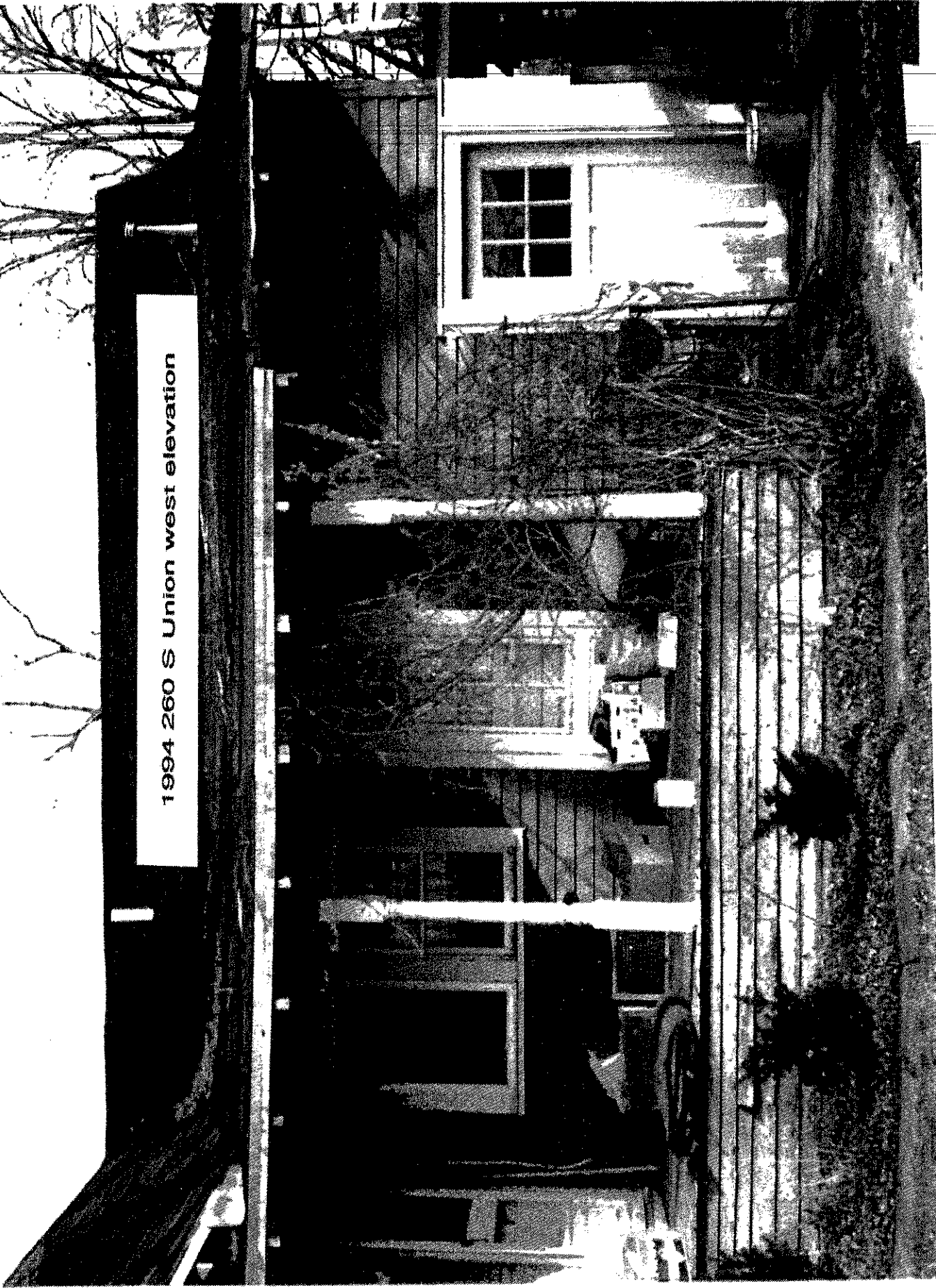



City of Plymouth Historic District Commission  
201 S. Main Plymouth, MI 48170  
Administrative Review of 260 S. Union  
Case Number H19-10  
Agenda Date: January 9, 2020

Address: 260 S. Union  
Year Built: Unknown, Remodeled 1923  
Historical Significance: Architecture

Proposed Changes: Replace Railings/Balusters on Rear Porch

*Standards for Rehabilitation*

1. A property will be used as it was historically or be given a new use that requires minimal change to its distinctive materials, features, spaces, and spatial relationships.
2. The historic character of a property will be retained and preserved. The removal of distinctive materials or alteration of features, spaces, and spatial relationships that characterize a property will be avoided.
3. Each property will be recognized as a physical record of its time, place, and use. Changes that create a false sense of historical development, such as adding conjectural features or elements from other historic properties, will not be undertaken.
4. Changes to a property that have acquired historic significance in their own right will be retained and preserved.
5. Distinctive materials, features, finishes, and construction techniques or examples of craftsmanship that characterize a property will be preserved.
6. Deteriorated historic features will be repaired rather than replaced. Where the severity of deterioration requires replacement of a distinctive feature, the new feature will match the old in design, color, texture, and, where possible, materials. Replacement of missing features will be substantiated by documentary and physical evidence.
7. Chemical or physical treatments, if appropriate, will be undertaken using the gentlest means possible. Treatments that cause damage to historic materials will not be used.
8. Archeological resources will be protected and preserved in place. If such resources must be disturbed, mitigation measures will be undertaken.
9. New additions, exterior alterations, or related new construction will not destroy historic materials, features, and spatial relationships that characterize the property. The new work shall be differentiated from the old and will be compatible with the historic materials, features, size, scale and proportion, and massing to protect the integrity of the property and its environment.
10. New additions and adjacent or related new construction will be undertaken in such a manner that, if removed in the future, the essential form and integrity of the historic property and its environment would be unimpaired.

## **SAMPLE MOTION LANGUAGE**

### **1. Motion to Approve Application**

I move that the Commission issue a Certificate of Appropriateness for application number \_\_. The Findings of Fact are as follows: (list facts of finding). The work as proposed meets the Secretary of the Interior's Standards for Rehabilitation standard number(s) \_\_ and would give consideration and/or significance to the City of Plymouth Ordinance review criteria number(s) \_\_. Vote "Yes" to approve application. Vote "No" to deny application.

### **2. Motion to Approve Application with Conditions**

I move that the Commission issue a Certificate of Appropriateness for application number \_\_, provided that the following conditions are met: (list conditions). The Findings of Fact are as follows: (list facts of finding). The work would then meet the Secretary of the Interior's Standards for Rehabilitation, standard number(s) \_\_ and would give consideration and/or significance to the following City of Plymouth Ordinance review criteria number(s) \_\_. Vote "Yes" to approve application with conditions. Vote "No" to deny application with conditions.

### **3. Motion to Postpone Review**

I move that the Commission Postpone Review of application number \_\_ until the next regular meeting scheduled for \_\_. Vote "Yes" to approve postponing the review. Vote "No" to deny postponing the review.

### **4. Motion to Deny Application**

I move that the Commission issue a Certificate of Appropriateness for application number \_\_. The Findings of Fact are as follows: (list findings of facts that do not warrant the project's approval). The work as proposed does not meet the Secretary of the Interior's Standards for Rehabilitation, standard number(s) \_\_ and would not give consideration and/or significance to the following City of Plymouth Ordinance review criteria number(s) \_\_. Vote "No" to deny the application. Vote "Yes" to approve the application.

*Note:* Voting "No" to positively framed motion is the easiest way to deny an application's request for a Certificate of Appropriateness. FYI: Making a motion for approval and then voting "No" to deny is the same as making a motion to deny an application and then voting "Yes".

### **5. Motion to Issue a Notice to Proceed**

#### **May be used in special conditions or emergencies.**

I move that the Commission issue a Notice to Proceed for application number \_\_. The Findings of Fact are as follows: (list facts of finding). The work as proposed does (not) meet the Secretary of the Interior's Standards for Rehabilitation, standard number(s) \_\_ and would (not) give consideration and/or significance to the following City of Plymouth Ordinance review criteria number(s) \_\_. The work which is approved with this Notice to Proceed is as follows: (list approved work). The work that is not approved/not appropriate requires the following conditions to be met: (list conditions). The proposed work will substantially improve or correct the following: (list notice to proceed options). Additional work desired which is not approved within this Notice to Proceed is to be resubmitted for a Certificate of Appropriateness. Vote "Yes" to approve notice to proceed. Vote "No" to deny notice to proceed.

# APPLICATION FOR DETERMINATION OF APPROPRIATENESS

Please consult the following submittal checklist to ensure you submit a complete application and supporting information about the type of work proposed. \* 583, 585 Ann Arbor trail is the Jewell building

Property Location (Address of Work): 587 Ann Arbor trail, \* building

Contributing Structure  Non-Contributing Structure 686, 674 Maple

Building Owner: City of Plymouth

Building Owner Address: 291 S. Main

Phone: 734-453-1234 Email: J Buehvis @

Applicant: Jewell Maple Development Plymouth MI. 900

Phone: 460 602442 734-846-8045 Email: ldgers@aol.com Mike Ferrantino 313-670-3777 m.ferrantino@eohio.com

Applicant's Role:  Building Owner  Architect  Contractor  Other Developer

**TYPE OF WORK PROPOSED (Check all that apply):**

- New Construction (TOWNHOUSES)
- Addition
- Alteration
- Window Replacement
- Door Replacement
- Roof Replacement
- Siding Replacement
- Sign / Awning Install / Replacement
- Fence Install / Replacement
- Paving Install / Replacement
- Wall Install / Replacement
- Landscaping Install / Replacement
- Porch Reconstruction/Repair
- Paint Color Change
- Building Cleaning
- Other SUNSCREENS & AWNINGS  
DEMO (2) HOUSES

**Application Deadline:** The Historic District Commission typically meets the first Wednesday of each month. Please confirm meeting date as meeting schedules may change due to holidays or other unforeseen circumstances. Application material must be completed and submitted to the Community Development Department by 3:00PM on the third Monday of the previous month in order to be placed on the agenda for the following month's meeting. Please check the city's website for exact submission deadlines.

**PLEASE PROVIDE TEN (10) COPIES OF ALL SUBMITTALS**

Submittal must include index of sheets (what is included) and all sheets must be numbered and dated.

Applicant's Signature [Signature] Date 7-22-2019  
L. G. Gonzalez

I, as the Building Owner, confirm with my signature below that I am aware of and approve the work proposed.

**RECEIVED**

H19-06 587 W. Ann Arbor Trail  
New townhome construction, demo of 2  
homes, remodeling of Jewell bldg.,  
landscaping & paving.  
HD Mtg 8/7/19

Date  
JUL 22 2019  
CITY OF PLYMOUTH  
COMMUNITY DEVELOPMENT

# SUBMITTAL CHECKLIST

## New Construction / Additions / Alterations:

- Completed Application for Determination of Appropriateness
- Synopsis: description of the project in words
- Completed materials finish list
- Detailed justification of why items need to be altered, added on to, or newly constructed
- Historic photographs of the site and building
- Photographs of site and building as they exist today
- Scaled drawings including, but not limited to:
  - existing and proposed site plan showing all property lines, easements, setbacks, changes and landscape features
  - existing and proposed floor plans
  - existing and proposed elevations
  - existing and proposed cross sections and other details as needed
  - material samples and colors for roofing, siding, and trim
  - complete list and specific information on all exterior materials (windows, doors, garage doors, exterior lighting and fencing) including manufacturer's name, brochure, colors, textures and finish / materials
  - statement of impact of the new construction/additions/alterations on surrounding properties and buildings such as architectural character, building scale, vehicular and pedestrian traffic, mass, form, proportion, configuration, location on site, landscaping and visual appearance
- the time frame for the project including an approximate start date, exterior completion date, landscaping completion date, and occupation date
- Color exterior elevation and/or rendering of the proposed building, addition and / or alteration
- New construction or a substantial addition requires a streetscape view (to scale) with the proposed new project inserted

MIKE / WEO

## Proposed Replacement Projects:

- Completed Application for Determination of Appropriateness
- Synopsis: description of the project in words
- Completed materials finish list
- Detailed justification of why item(s) need to be replaced
- Historic photographs of the site and building
- Photographs of the existing materials proposed for replacement or maintenance and repair
- Photographs of existing site and building with proposed changes indicated
- Description of existing material and color (provide sample if possible)
- Manufacturer's brochures, data sheets, color samples, material samples of proposed materials to be used and what they are replacing

## Window Replacement:

- The information listed under Proposed Replacement Projects as well as:
  - Number of windows to be replaced
  - Dimensions of all windows especially frame width and thickness
  - Photographs of all four sides of the existing building indicating affected windows
  - Photographs of other projects incorporating these replacement components

### Door and Garage Door Replacement:

- The information listed under Proposed Replacement Projects as well as:
- Number of doors to be replaced
- Dimensions of all doors especially frame width and thickness
- Photographs of all four sides of the existing building indicating affected doors
- Photographs of other projects incorporating these replacement components

### Roof Replacement:

- The information listed under Proposed Replacement Projects as well as:
- Material samples (for asphalt shingles, a 3"x3" piece is sufficient)
- Dimensions of proposed replacement roof
- Detailed description of proposed work, including related work such as gutters, soffit and fascia
- Photographs of other projects incorporating these replacement components

### Siding Replacement:

- The information listed under Proposed Replacement Projects as well as:
- Material samples
- A set of scaled and dimensioned elevations
- Dimensions of proposed replacement siding
- Detail description of proposed work, including related work such as trim and details
- Photographs of other projects incorporating these replacement components

### Sign and Awning Installation/Replacement:

- Completed Application for Determination of Appropriateness
- Synopsis: description of the project in words
- Completed materials finish list
- Detailed justification of why signs/awnings need to be replaced/installed
- Historic photographs of the site and building
- Photographs of site and building as they exist today
- Number / letter, font size, color and material sample
- Scaled and dimensioned drawing of the front and side elevations indicating size and location of the proposed signage / awning
- Scaled cross-section drawing of building elevation indicating proposed signage / awning
- Detailed description including the colors, materials and location(s) of existing signs
- Identification of all materials to be used in the construction of the sign and / or awning

(A)  
ELECTRONIC  
SAMPLES...  
ACTUAL  
SAMPLES  
AT HBC  
MEETG.

**Fence, Paving, Walls, Landscaping Installation / Removal:**

- Completed Application for Determination of Appropriateness
- Synopsis: description of the project in words
- Completed materials finish list
- Detailed justification of why item(s) need to be installed/removed
- Historic photographs of the site and building
- Photographs of site and building as they exist today
- Scaled and dimensioned site plan showing:
  - existing lot lines
  - existing buildings
  - location and dimensions of existing and proposed sidewalks, driveways, fencing (including height), landscape materials and other landscape features
  - location of the adjacent structures
- Photographs of the existing site with proposed changes indicated
- Material and color samples from fencing, walls, paving
- Brochure(s) showing fencing and other manufactured landscape items proposed

**Porch Reconstruction and Other Repairs:**

- Completed Application for Determination of Appropriateness
- Synopsis: description of the project in words
- Completed materials finish list
- Detailed justification of why item(s) need to be reconstructed/repared
- Historic photographs of the site and building
- Photographs of the site and building as they exist today
- Description of existing materials and property
- A description of the proposed replacement materials and colors (including samples if possible)
- A set of scaled and dimensioned drawings that include:
  - existing and proposed site plan showing all changes
  - existing and proposed floor plans
  - existing and proposed elevation
  - existing and proposed sections and other details as needed

**Paint Color Change:**

- Completed Application for Determination of Appropriateness
- Synopsis: description of the project in words
- Completed materials finish list
- Historic photographs of the site and building
- Photographs of the site and building as they exist today
- Samples of the proposed paint color (i.e., paint chips) and a list of locations where paint color will be applied, along with photographs and / or diagrams showing locations

**Building Cleaning:**

- Completed Application for Determination of Appropriateness
- Synopsis: description of the project in words
- Completed materials finish list
- Historic photographs of the site and building
- Photographs of the site and building as they exist today
- A description of the cleaning method, including the names of chemicals and the pressure of any washes or application(s)
- Brochures for cleaning agents
- A description of the surface treatment after cleaning (i.e. material, color, brick / mortar)











City of Plymouth Historic District Commission  
201 S. Main Plymouth, MI 48170  
Administrative Review of Jewell Maple Development  
Case Number H19-06  
Agenda Date: January 9, 2020

Address: 583-585 W. Ann Arbor Trail  
Commonly Known As: Jewell Blaiich Hall  
Year Built: 1926  
Historical Significance: Architecture

Proposed Changes: Partial Demolition, New Windows, New Sunshades, New Doors, New Roof, New Siding, Building Cleaning

*Standards for Rehabilitation*

1. A property will be used as it was historically or be given a new use that requires minimal change to its distinctive materials, features, spaces, and spatial relationships.
2. The historic character of a property will be retained and preserved. The removal of distinctive materials or alteration of features, spaces, and spatial relationships that characterize a property will be avoided.
3. Each property will be recognized as a physical record of its time, place, and use. Changes that create a false sense of historical development, such as adding conjectural features or elements from other historic properties, will not be undertaken.
4. Changes to a property that have acquired historic significance in their own right will be retained and preserved.
5. Distinctive materials, features, finishes, and construction techniques or examples of craftsmanship that characterize a property will be preserved.
6. Deteriorated historic features will be repaired rather than replaced. Where the severity of deterioration requires replacement of a distinctive feature, the new feature will match the old in design, color, texture, and, where possible, materials. Replacement of missing features will be substantiated by documentary and physical evidence.
7. Chemical or physical treatments, if appropriate, will be undertaken using the gentlest means possible. Treatments that cause damage to historic materials will not be used.
8. Archeological resources will be protected and preserved in place. If such resources must be disturbed, mitigation measures will be undertaken.
9. New additions, exterior alterations, or related new construction will not destroy historic materials, features, and spatial relationships that characterize the property. The new work shall be differentiated from the old and will be compatible with the historic materials, features, size, scale and proportion, and massing to protect the integrity of the property and its environment.
10. New additions and adjacent or related new construction will be undertaken in such a manner that, if removed in the future, the essential form and integrity of the historic property and its environment would be unimpaired.

Address: 587 W. Ann Arbor Trail  
Commonly Known As: Saxton's Building and public parking lot  
Year Built: 1960, enclosed in 1965  
Historical Significance: Non-contributing

Proposed Changes: Partial Demolition, Updated Surface Parking Lot, New Parking Lot Landscaping

**Sec. 18-654. - Duties and powers.**

(a) It shall be the duty of the historic district commission to review all plans for the construction, addition, alteration, repair, moving, excavation or demolition of structures in the historic district and it shall have the power to pass upon such plans before a permit for such activity can be granted. In reviewing the plans, the commission shall follow the U.S. Secretary of the Interior's standards for rehabilitation and guidelines for rehabilitating historic buildings, as set forth in 36 CFR 67, or their equivalent as approved or established by the state bureau of history of the department of state, and shall also give consideration and significance to:

- (1) The historical or architectural value and significance of the historic resource and its relationship to the historic value of the surrounding area;
- (2) The relationship of the exterior architectural features of such historic resource to the rest of the resources and to the surrounding area;
- (3) The general compatibility of the exterior design, arrangement, texture and materials proposed to be used;
- (4) To any other factor, including aesthetics, which it deems pertinent;
- (5) The proposed major changes to open spaces in a historic district. The HDC shall review plans for major changes to these open spaces, such as the removal of large trees (over 12 inches in diameter as measured four feet above ground) or the making of major contour changes in terrain features. The HDC may use its discretion to decide if proposed changes are major in nature or not.

(b) The HDC shall review and act upon exterior features of a resource, and shall not review and act upon interior arrangements unless interior work will cause visible changes to the exterior of the historic resource. The HDC shall not disapprove applications except in regard to considerations as set forth in subsection (a) of this section.

(c) The HDC may delegate the issuance of certificates of appropriateness for specified minor classes of work to its staff, to the inspector of buildings, or to another delegated authority. The HDC shall provide to such delegated authorities specific written standards for issuing the certificates of appropriateness under this subsection. Such delegated authorities shall come before the next regularly scheduled HDC meeting and the HDC shall review the certificates of appropriateness so issued. These reviews are to serve the purpose of keeping the HDC informed as to what certificates of appropriateness for minor work have been issued since the last HDC meeting. On a quarterly basis, the HDC shall review the certificates of appropriateness, if any, issued by the aforesaid delegated authority to determine whether or not the delegated responsibilities should be continued.

(d) In case of an application for work affecting the appearance of a resource or for the alteration, moving or demolition of a resource which the commission deems so valuable to the city that the loss thereof will adversely affect the public purpose of the city, the historic district commission shall endeavor to work out with the owner an economically feasible plan for preservation of the historic resource.

Address: 674 Maple  
Year Built: Unknown, likely prior to 1920  
Historical Significance: Architecture

Proposed Changes: New Construction

---

---

**Sec. 18-654. - Duties and powers.**

- (a) It shall be the duty of the historic district commission to review all plans for the construction, addition, alteration, repair, moving, excavation or demolition of structures in the historic district and it shall have the power to pass upon such plans before a permit for such activity can be granted. In reviewing the plans, the commission shall follow the U.S. Secretary of the Interior's standards for rehabilitation and guidelines for rehabilitating historic buildings, as set forth in 36 CFR 67, or their equivalent as approved or established by the state bureau of history of the department of state, and shall also give consideration and significance to:
- (1) The historical or architectural value and significance of the historic resource and its relationship to the historic value of the surrounding area;
  - (2) The relationship of the exterior architectural features of such historic resource to the rest of the resources and to the surrounding area;
  - (3) The general compatibility of the exterior design, arrangement, texture and materials proposed to be used;
  - (4) To any other factor, including aesthetics, which it deems pertinent;
  - (5) The proposed major changes to open spaces in a historic district. The HDC shall review plans for major changes to these open spaces, such as the removal of large trees (over 12 inches in diameter as measured four feet above ground) or the making of major contour changes in terrain features. The HDC may use its discretion to decide if proposed changes are major in nature or not.
- (b) The HDC shall review and act upon exterior features of a resource, and shall not review and act upon interior arrangements unless interior work will cause visible changes to the exterior of the historic resource. The HDC shall not disapprove applications except in regard to considerations as set forth in subsection (a) of this section.
- (c) The HDC may delegate the issuance of certificates of appropriateness for specified minor classes of work to its staff, to the inspector of buildings, or to another delegated authority. The HDC shall provide to such delegated authorities specific written standards for issuing the certificates of appropriateness under this subsection. Such delegated authorities shall come before the next regularly scheduled HDC meeting and the HDC shall review the certificates of appropriateness so issued. These reviews are to serve the purpose of keeping the HDC informed as to what certificates of appropriateness for minor work have been issued since the last HDC meeting. On a quarterly basis, the HDC shall review the certificates of appropriateness, if any, issued by the aforesaid delegated authority to determine whether or not the delegated responsibilities should be continued.
- (d) In case of an application for work affecting the appearance of a resource or for the alteration, moving or demolition of a resource which the commission deems so valuable to the city that the loss thereof will adversely affect the public purpose of the city, the historic district commission shall endeavor to work out with the owner an economically feasible plan for preservation of the historic resource.

Address: 686 Maple  
Year Built: 1920  
Historical Significance: Architecture

Proposed Changes: New Construction

---

---

**Sec. 18-654. - Duties and powers.**

- (a) It shall be the duty of the historic district commission to review all plans for the construction, addition, alteration, repair, moving, excavation or demolition of structures in the historic district and it shall have the power to pass upon such plans before a permit for such activity can be granted. In reviewing the plans, the commission shall follow the U.S. Secretary of the Interior's standards for rehabilitation and guidelines for rehabilitating historic buildings, as set forth in 36 CFR 67, or their equivalent as approved or established by the state bureau of history of the department of state, and shall also give consideration and significance to:
- (1) The historical or architectural value and significance of the historic resource and its relationship to the historic value of the surrounding area;
  - (2) The relationship of the exterior architectural features of such historic resource to the rest of the resources and to the surrounding area;
  - (3) The general compatibility of the exterior design, arrangement, texture and materials proposed to be used;
  - (4) To any other factor, including aesthetics, which it deems pertinent;
  - (5) The proposed major changes to open spaces in a historic district. The HDC shall review plans for major changes to these open spaces, such as the removal of large trees (over 12 inches in diameter as measured four feet above ground) or the making of major contour changes in terrain features. The HDC may use its discretion to decide if proposed changes are major in nature or not.
- (b) The HDC shall review and act upon exterior features of a resource, and shall not review and act upon interior arrangements unless interior work will cause visible changes to the exterior of the historic resource. The HDC shall not disapprove applications except in regard to considerations as set forth in subsection (a) of this section.
- (c) The HDC may delegate the issuance of certificates of appropriateness for specified minor classes of work to its staff, to the inspector of buildings, or to another delegated authority. The HDC shall provide to such delegated authorities specific written standards for issuing the certificates of appropriateness under this subsection. Such delegated authorities shall come before the next regularly scheduled HDC meeting and the HDC shall review the certificates of appropriateness so issued. These reviews are to serve the purpose of keeping the HDC informed as to what certificates of appropriateness for minor work have been issued since the last HDC meeting. On a quarterly basis, the HDC shall review the certificates of appropriateness, if any, issued by the aforesaid delegated authority to determine whether or not the delegated responsibilities should be continued.
- (d) In case of an application for work affecting the appearance of a resource or for the alteration, moving or demolition of a resource which the commission deems so valuable to the city that the loss thereof will adversely affect the public purpose of the city, the historic district commission shall endeavor to work out with the owner an economically feasible plan for preservation of the historic resource.

Historic District Commission Sample Resolution

The following resolution was offered by Commissioner \_\_\_\_\_ and seconded by  
Commissioner \_\_\_\_\_:

WHEREAS The City of Plymouth Historic District Commission has reviewed the request for a Certificate of Appropriateness for Jewell Maple Development, Case H19-06 and determined that the buildings involved are both contributing and non-contributing structures, and

WHEREAS The City of Plymouth Historic District Commission has determined that the proposed demolition and alterations comply with the application of the Secretary of Interior Standards numbers: \_\_\_\_, \_\_\_\_, \_\_\_\_, and City of Plymouth Ordinance 18-654 subsections: \_\_\_\_, \_\_\_\_, \_\_\_\_, and

WHEREAS The City of Plymouth Historic District Commission requires the following conditions:

NOW THEREFORE BE IT RESOLVED THAT THE CITY OF PLYMOUTH HISTORIC DISTRICT COMMISSION HEREBY APPROVES THE PROPOSED PROJECT H19-06 FOR THE ISSUANCE OF A CERTIFICATE OF APPROPRIATENESS REFERENCING THE SECRETARY OF INTERIOR STANDARDS NUMBERS: \_\_\_\_, \_\_\_\_, \_\_\_\_, AND CITY OF PLYMOUTH ORDINANCE 18-654 SUBSECTIONS: \_\_\_\_, \_\_\_\_, \_\_\_\_,.

NOW THEREFORE BE IT RESOLVED THAT THE CITY OF PLYMOUTH HISTORIC DISTRICT COMMISSION REQUIRES THE FOLLOWING CONDITIONS TO BE ATTACHED TO THE CERTIFICATE OF APPROPRIATENESS FOR H19-06:

# APPLICATION FOR DETERMINATION OF APPROPRIATENESS

Please consult the following submittal checklist to ensure you submit a complete application and supporting information about the type of work proposed.

Property Location (Address of Work): Downtown Plymouth - site TBD - proposed

Contributing Structure  Non-Contributing Structure map attached

<sup>Project</sup>  
Building Owner: DIA - DDA - Plymouth Community Arts Council

<sup>Project</sup>  
Building Owner Address: 774 N. Sheldon, Plymouth, MI 48170

Phone: 734.416.4270 Email: lisa@plymoutharts.com

Applicant: Lisa Howard (PCAC), Charles Earling (DIA), Tony Bruscati (DDA)

Phone: 734.416.4270 Email: lisa@plymoutharts.com

Applicant's Role:  Building Owner  Architect  Contractor  Other Community Partner

TYPE OF WORK PROPOSED (Check all that apply):

- |   |  |   |
|---|--|---|
| <input type="checkbox"/> New Construction   | <input type="checkbox"/> Sign / Awning Install / Replacement | <input type="checkbox"/> Porch Reconstruction/Repair                    |
| <input type="checkbox"/> Addition           | <input type="checkbox"/> Fence Install / Replacement         | <input type="checkbox"/> Paint Color Change                             |
| <input type="checkbox"/> Alteration         | <input type="checkbox"/> Paving Install / Replacement        | <input type="checkbox"/> Building Cleaning                              |
| <input type="checkbox"/> Window Replacement | <input type="checkbox"/> Wall Install / Replacement          | <input checked="" type="checkbox"/> Other <u>sculpture installation</u> |
| <input type="checkbox"/> Door Replacement   | <input type="checkbox"/> Landscaping Install / Replacement   |   |
| <input type="checkbox"/> Roof Replacement   |  |   |
| <input type="checkbox"/> Siding Replacement |  |   |

**Application Deadline:** The Historic District Commission typically meets the first Wednesday of each month. Please confirm meeting date as meeting schedules may change due to holidays or other unforeseen circumstances. Application material must be completed and submitted to the Community Development Department by 3:00PM on the third Monday of the previous month in order to be placed on the agenda for the following month's meeting. Please check the city's website for exact submission deadlines.

## PLEASE PROVIDE TEN (10) COPIES OF ALL SUBMITTALS

Submittal must include index of sheets (what is included) and all sheets must be numbered and dated.

M. Lisa Howard  
Applicant's Signature

12/19/2019  
Date

I, as the Building Owner, confirm with my signature below that I am aware of and approve the work proposed.

Tony Bruscati  
Building Owner's Signature

12-19-19  
Date

DEC 19 2019

+ 20-01 381 S. Main  
Sculpture  
HD Mtg 1/9/20



The Plymouth  
Community  
Arts Council

774 N. Sheldon Road  
Plymouth, MI 48170  
Ph: 734.416.4278

[www.plymoutharts.com](http://www.plymoutharts.com)

Board of Directors

Florence Erzen  
*Community Arts Advocate*  
PRESIDENT

Suzanne Parent  
*PCAC Volunteer - PCCS*  
VICE PRESIDENT

Steve Sneiderman  
*AT&T*  
TREASURER

Cindy Patrick  
*Community Arts Advocate*  
SECRETARY

Jim Craven  
*McQueen Financial Advisors*

William Lawton  
*Community Financial Credit Union*

Nancy Tymensky  
*Art Educator*  
*Ann Arbor Schools*

PCAC Staff

Lisa Howard  
Executive Director  
*Programming & Development*

Shelia Graham  
*Executive Assistant*

Pam Seymour  
*Bookkeeper*  
*CTA & Associates, LLC*

Tipping Point Theatre  
*Performing Arts*

December 17, 2019

Dear Plymouth City Manager, Historic District Commission and other interested individuals:

On December 9, 2019, Lisa Howard, Executive Director of the PCAC, Charlie Garling from the Detroit Institute of Arts, and Sculptor Vito Valdez presented a Community Partnership Public Art sculpture project to the Plymouth DDA Board. The Board reviewed the submission and is supportive of the collective group (DIA, DDA and PCAC) moving through the process toward implementation.

Please find attached the Application for Determination of Appropriateness and statement addressing the issues related to the Establishment of a Monument (section 9).

We hope to present the project in detail and take commission questions at the January 9, 2020 HDC meeting.

Thank you,

Lisa Howard  
Executive Director

[lisa@plymoutharts.com](mailto:lisa@plymoutharts.com)

DIA – Plymouth DDA – Plymouth Community Arts Council

1  
12/19

Community Partnership Sculpture Project – Request for City of Plymouth Site Installation

Application Packet Index:

HDC Application

Page 1 Index, Contacts, Project details

Page 2 Project details continued, Potential site photograph

Page 3 Potential site map location

Page 4 Artist rendering A

Page 5 Artist rendering B

Page 6 Artist rendering C

Page 7-8 Section 9 - Establishing A Monument, Requirements addressed

Auxiliary Packet – Complete project overview prepared by Charles Garling, Detroit Institute of Arts

Partner contacts:

Charles Garling, DIA Director, Studio Programs 313.578.6923 cgarling@dia.org

Vito J. Valdez, Sculptor- Partners in Public Art, Studio: 313.530.2710

Tony Bruscato, Plymouth Downtown Development Authority abruscato@plymouthmi.gov

Lisa Howard, Executive Director, Plymouth Community Arts Council 734-416-4278 lisa@plymoutharts.com

**Introduction:** Earlier this year, we were contacted by the DIA to explore a potential partnership to co-create a work of public art in Plymouth together with the Plymouth community. The DIA is planning on working on two of these projects in Wayne County, and we would like one of those partnerships to be with us!

This is the second year of the DIA's Community Art Partnership Program, where the DIA works with cities and local organizations to help people explore, express, and strengthen their sense of community through a communal art-making experience.

Past and current partners of this program include the Clarkston Cultural Arts Council, Detroit's Osborn Neighborhood Alliance, and the City of Sterling Heights and the Sterling Heights Police Department.

**Siting of the sculpture:** After exploring many locations for this public art piece in our city, we have selected a potential city-owned venue with high visibility and lots of foot traffic. The location at the corner of Ann Arbor Trail \*\* and Union/Deer Street marks the eastern gateway into our city, across from the former Saxton's property. A public art piece here would serve as a great source of pride, a landmark gathering place, and an ideal welcome into the Kellogg Park business and event district. \*\*a historic native Potawatami trail

**Renderings:** The attached hand renderings are the artist's design concept of a sculptural planter and include references to our Plymouth heritage. These concepts listed below were taken from community responses to a DIA partnership survey distributed earlier this year by the DDA and PCAC via our electronic mailing lists, websites and physical locations. The results were collected and tabulated by Charles Garling at the DIA.

*Historic train depot Daisy and automotive industries City of Trees  
Native American rivers, trails and culture Growth, old + new past + future*

**Description of renderings:** The inside trellis design reflects railroads and auto industry, with a birdlike 1939 Plymouth car hood ornament center crest. Bottom shelves have locomotive and auto with factory illustrations. Columns made with Daisy factory bricks alongside native stone and rock. The planter will be made of concrete with tile leaves in mosaic all around. The leaf tiles would be created by Plymouth community members in the DIA studios and at the Plymouth Community Arts Council.

**Materials:**

Steel, concrete, Daisy Factory brick\*, high fire ceramic stoneware, chrome hood ornament, plants, flowers, earth and stone

**Additional Community Partners:** Brick will be sourced through Plymouth Preservation Network per Wendy Harless, [wmharless@gmail.com](mailto:wmharless@gmail.com)

Detroit Hot Rod has also pledged their support

Rendering references will be researched through the Plymouth Historical Museum and Plymouth District Library

**The costs for the project will be paid for by the DIA**



3

# CITY OF PLYMOUTH HISTORIC DISTRICT

Proposed installation site

11/19/2019

905	906	907	908	909	910	911	912	913	914	915	916	917	918	919	920	921	922	923	924	925	926	927	928	929	930	931	932	933	934	935	936	937	938	939	940	941	942	943	944	945	946	947	948	949	950	951	952	953	954	955	956	957	958	959	960	961	962	963	964	965	966	967	968	969	970	971	972	973	974	975	976	977	978	979	980	981	982	983	984	985	986	987	988	989	990	991	992	993	994	995	996	997	998	999	1000
-----	-----	-----	-----	-----	-----	-----	-----	-----	-----	-----	-----	-----	-----	-----	-----	-----	-----	-----	-----	-----	-----	-----	-----	-----	-----	-----	-----	-----	-----	-----	-----	-----	-----	-----	-----	-----	-----	-----	-----	-----	-----	-----	-----	-----	-----	-----	-----	-----	-----	-----	-----	-----	-----	-----	-----	-----	-----	-----	-----	-----	-----	-----	-----	-----	-----	-----	-----	-----	-----	-----	-----	-----	-----	-----	-----	-----	-----	-----	-----	-----	-----	-----	-----	-----	-----	-----	-----	-----	-----	-----	-----	-----	-----	-----	------



11.19.2019

Rendering A (4)

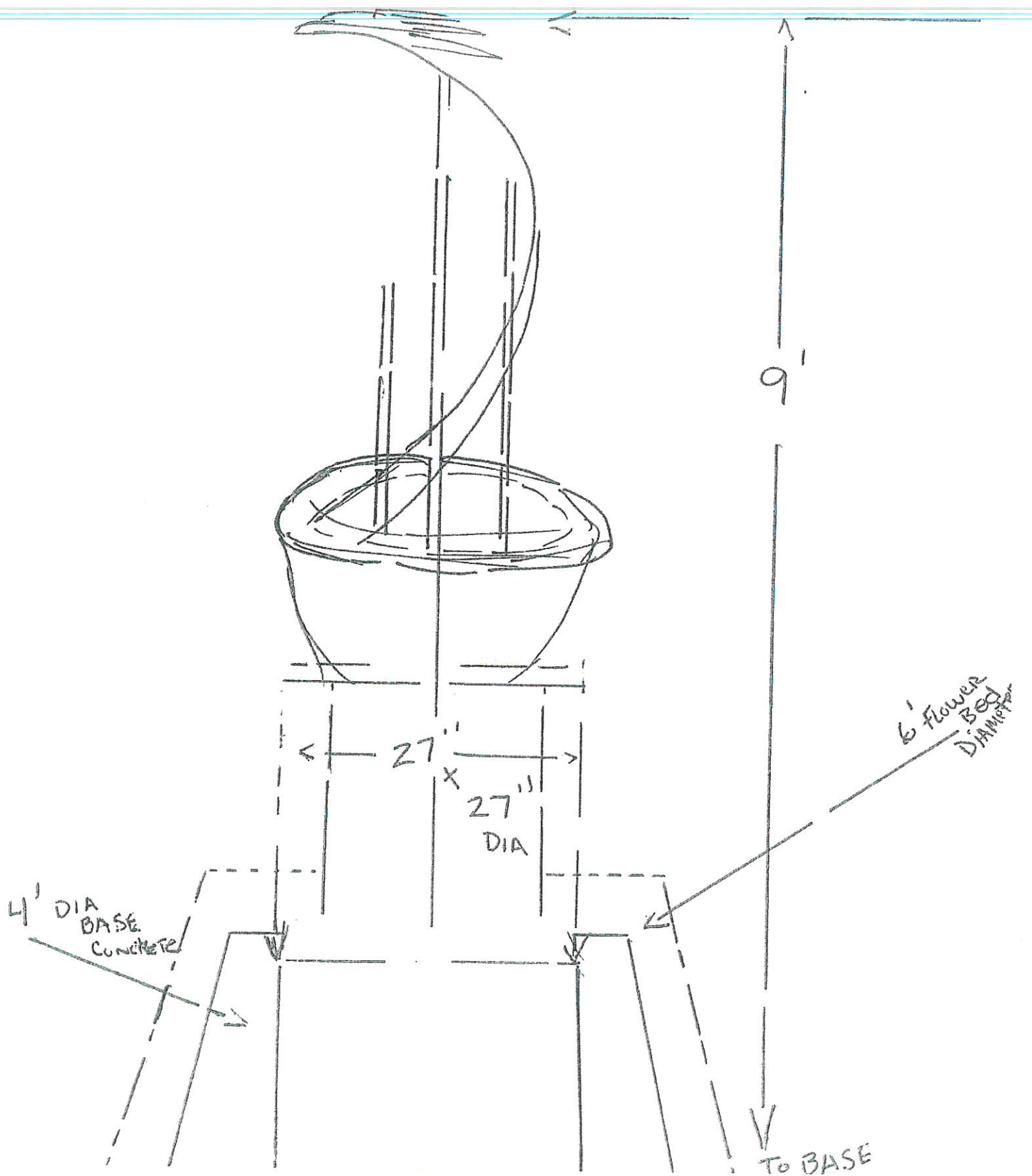

11.19.2019

Rendering B (5)

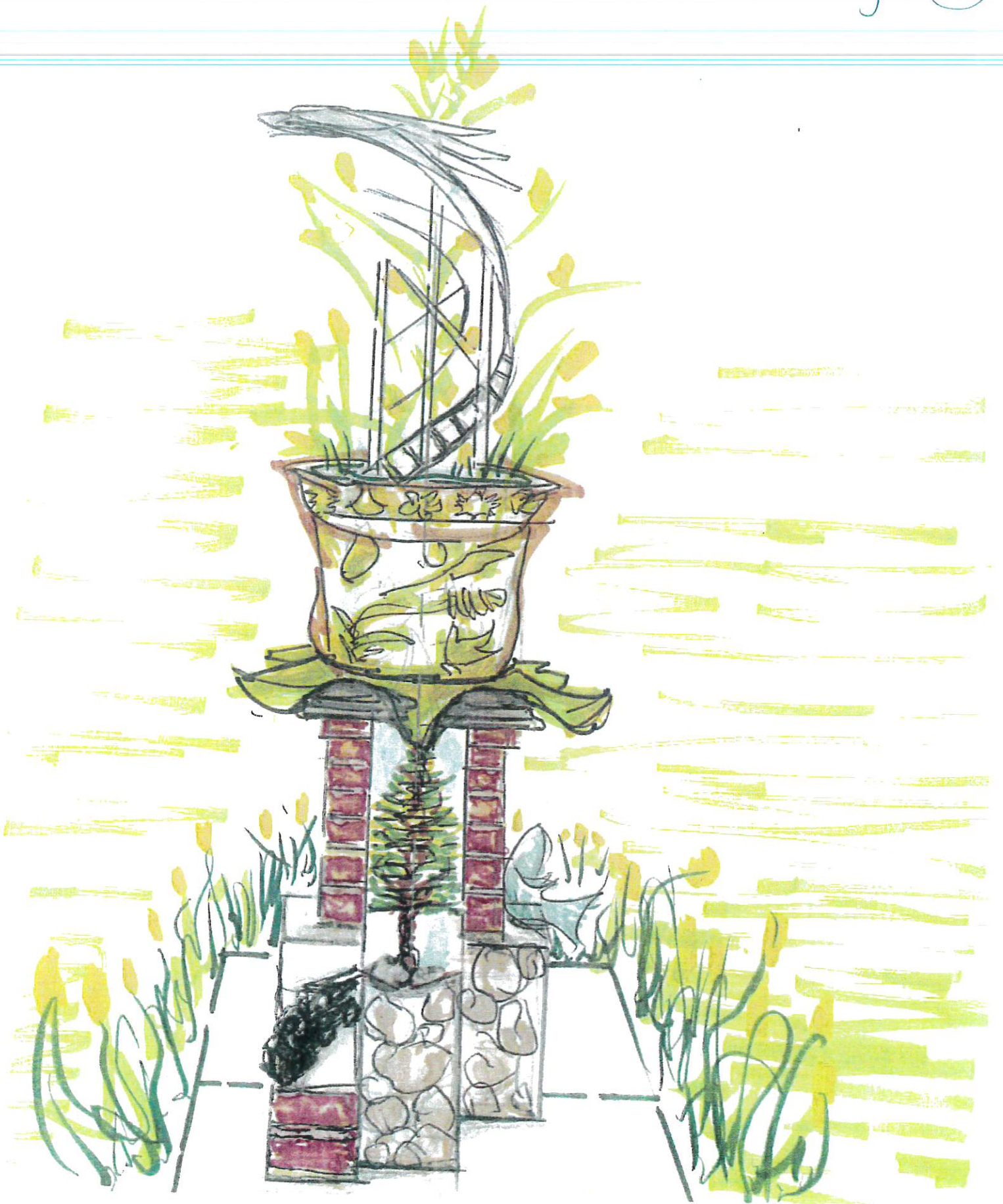

11-19-2019  
Rendering (C)  
(6)

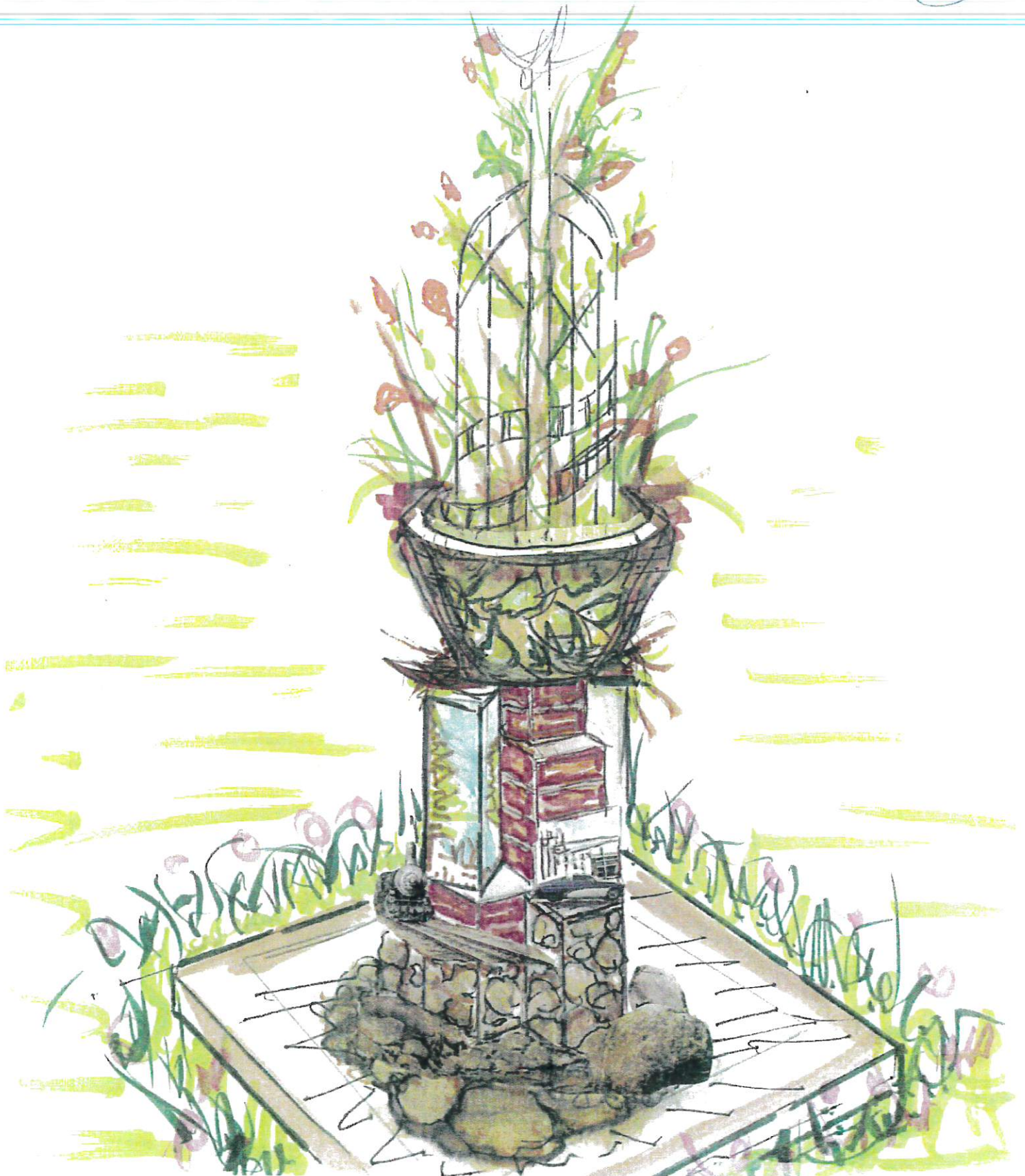

⑦  
12/19

## Proposing and Establishing an Art Sculpture Monument in the City of Plymouth

### A Community Arts Partnership - Detroit Institute of Arts, Plymouth Community Arts Council & Plymouth Downtown Development Authority

*Document prepared by Lisa Howard, PCAC*

#### Section 9

##### 9.2 Type of Monument

c. This will be an artistic monument installed in the City of Plymouth's Kellogg Park north triangle property in front of the Wilcox House sidewalk. This will be a major, one-of-a-kind item, donated by the DIA which will carry a plaque identifying the donation and community partners. In addition to the plaque, information about the sculpture will be written by the PCAC and made available to all interested entities for use on their webpages in reference to the art piece.

##### 9.3 Subject of Monument

a. This piece will represent the city (people and places) of Plymouth in artistic form, specifically our past, present and future. Please see the list of materials and their significance attached. Companion programming is planned for school groups, families, and visitors to be able to engage with the sculpture in a purposeful way.

##### Materials List:

**Brick** – Sourced through Wendy Harless and the Plymouth Preservation Network – these will be 1880s vintage Daisy Factory bricks (JSH John Smith Haggerty, Plymouth/Canton manufacturer)

**Metal** – the trellis part of the piece will be made of manipulated metal (Detroit Hot Rod)

**Stone** – locally sourced from the natural Plymouth, Michigan land – a nod to both the Native Potawatami and original settlers to our area of Michigan

**Living vines/plant material** – A metaphor for the growth of our community. Vines will root, climb and intertwine, blossom and so shall we. It is proposed that the living elements of the sculpture be maintained as part of the Plymouth DDA Planter Program, or under a sponsorship agreement by one of our local garden clubs.

**Community-made leaf tiles and pottery illustrative pieces** – Pottery clay tiles made by Plymouth people of all ages will be arranged to form a mosaic clad vessel near the base of the sculpture. Each tile will have a leaf impression on it, made by pressing a leaf from our Plymouth neighborhoods into the high-fire clay before firing. Pottery pieces will be made, glazed and fired at the DIA art studios and/or at the Plymouth Community Arts Council; this will be a true, hands-on community-made initiative. There will also be train and industry related pottery relief pieces. Samples will be provided.

**1939 Plymouth Automobile hood ornament** – This hood ornament will artistically represent the overall automobile manufacturing industry and the lifestyle it supported for many early (and current!) residents of our community. From Wikipedia...“The 1939 convertible coupe was prominently featured at Chrysler's exhibit at the 1939 New York World's Fair, advertised as the first mass-production convertible with a power folding top.” Sales of the Plymouth automobile were one of the few manufacturing bright spots during the Depression.

##### 9.4 Presentation

c. This project proposal is being presented by The Detroit Institute of Arts and the Plymouth Community Arts Council with permission from their organizations and Board of Directors. In addition, the project was presented to the Plymouth DDA Board on Monday, December 9, 2019.

## 9.5 Contents

a. Statement for Justification – Please see the narrative prepared by the Detroit Institute of Arts

b. Compliance, 9.2, 9.3 and 9.4 addressed above

c. Description of project – Please see complete project packet prepared by the DIA, including: site plan, nearby objects. Adjacent properties include: Wilcox House, Max & Bella's, tenant; Stan Dixon (Dickson?, property owner); Raymond James (tenant, Wilcox House); City-owned former Saxton's property.

d. Construction and maintenance finance plan - This project construction will be financed by the Detroit Institute of Arts. Insurance after installation should be covered by the City's blanket municipality insurance policy. This will of course need to be confirmed. It is our plan to use materials that will perform well in our changing seasonal weather. Occasional routine maintenance and cleaning of the structure would be the responsibility of the City of Plymouth. In case there are special cleaning circumstances, the sculptor would be consulted. The Plymouth Community Arts Council will continue to be involved in any aspect of the exhibition of the sculpture as needed.

## 9.6 Procedure for Authorizing a Monument

d. Located in the DDA District: This project has initial approval from the Plymouth DDA Board to engage in the process of being approved by everyone else.

e. Located in the Historic District: Currently engaged in getting approval to be included on the agenda for the January 9, 2020 HDC meeting.



## Partners in Public Art

### A partnership between the community of Plymouth and the Detroit Institute of Arts

#### Synopsis

The Detroit Institute of Arts wishes to partner with the Plymouth community to create a work of public art in downtown Plymouth that reflects their community. The DIA's Partners in Public Art program provides resources, funding, and expertise to create works of public art which are funded through the tri-county millage. Funding expires at the end of each calendar year.

Based on 82 responses from a 2019 online survey disseminated by the Plymouth Community Arts Council, the Plymouth community expressed interest in the following:

- Respondents enjoy seeing sculptures, murals, and interactive art
- Respondents desire a family-friendly sculpture or mural that reflects the community
- Respondents think the community can best be represented with depictions of history, family, and/or music. Native people/Native Americans was mentioned a few times, along with the historic Windmill)

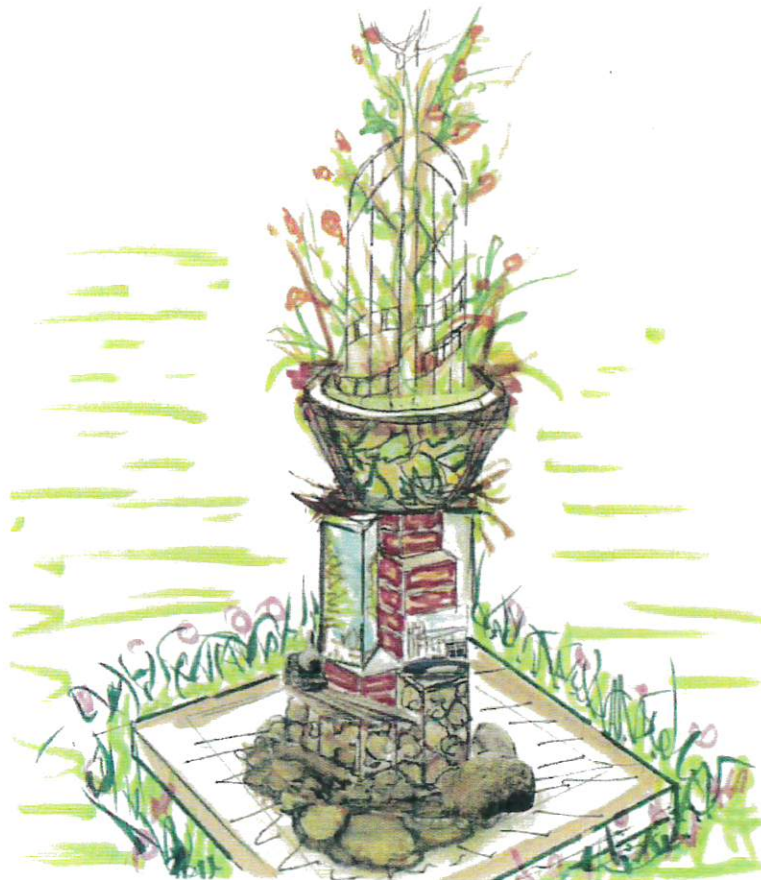

## Location

Numerous locations were considered:



Based on community survey results, conversations with residents, and input from the Plymouth Community Arts Council, the DIA proposes a sculpture on the Northeast corner of West Ann Arbor Trail and South Union Street, across the street from Kellogg Park.



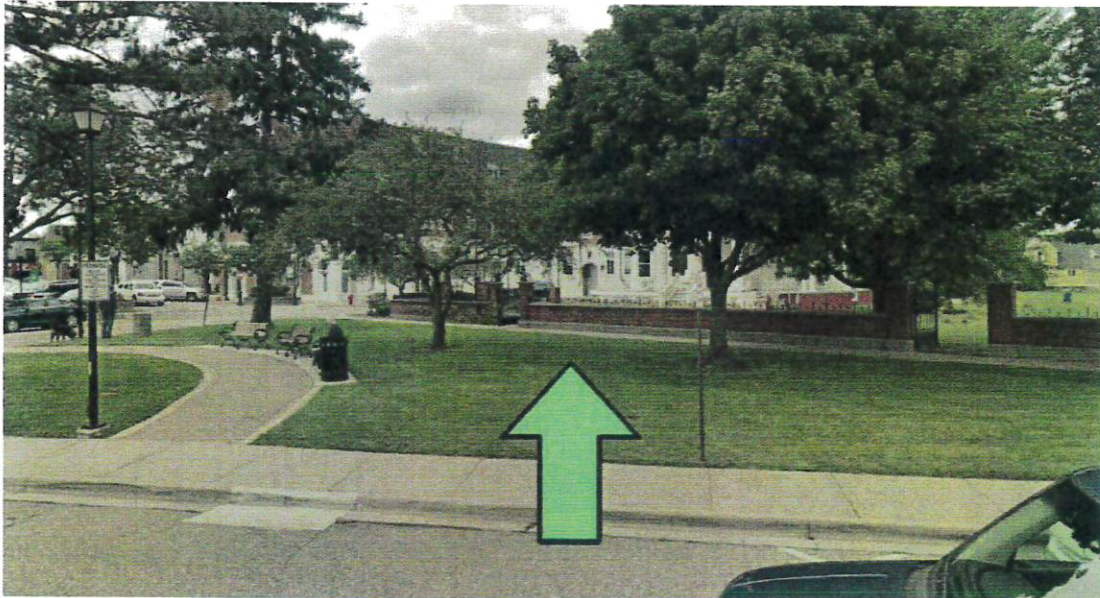
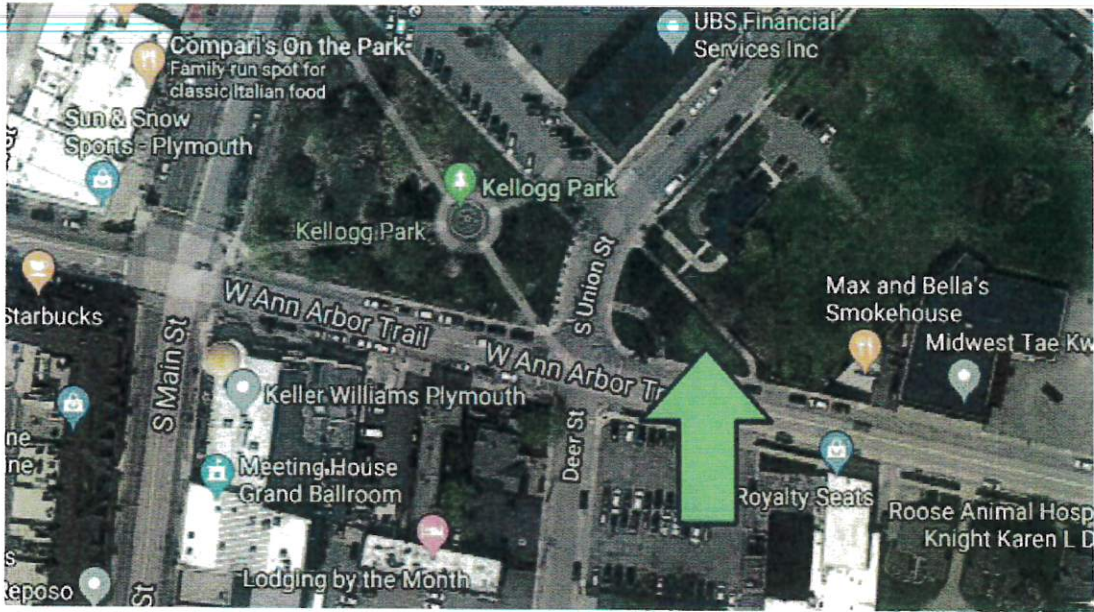

Project

The proposed project is a freestanding sculptural planter that reflects aspects of Plymouth's history, flora, historic train station, and Daisy Factory bricks from the Plymouth Preservation Network Trust. Materials for this planter include steel, brock, cinder blocks, stone, chrome, clay leaf impressions made by the community, and mortar. Below are sketch renderings from different angles and dimensions:

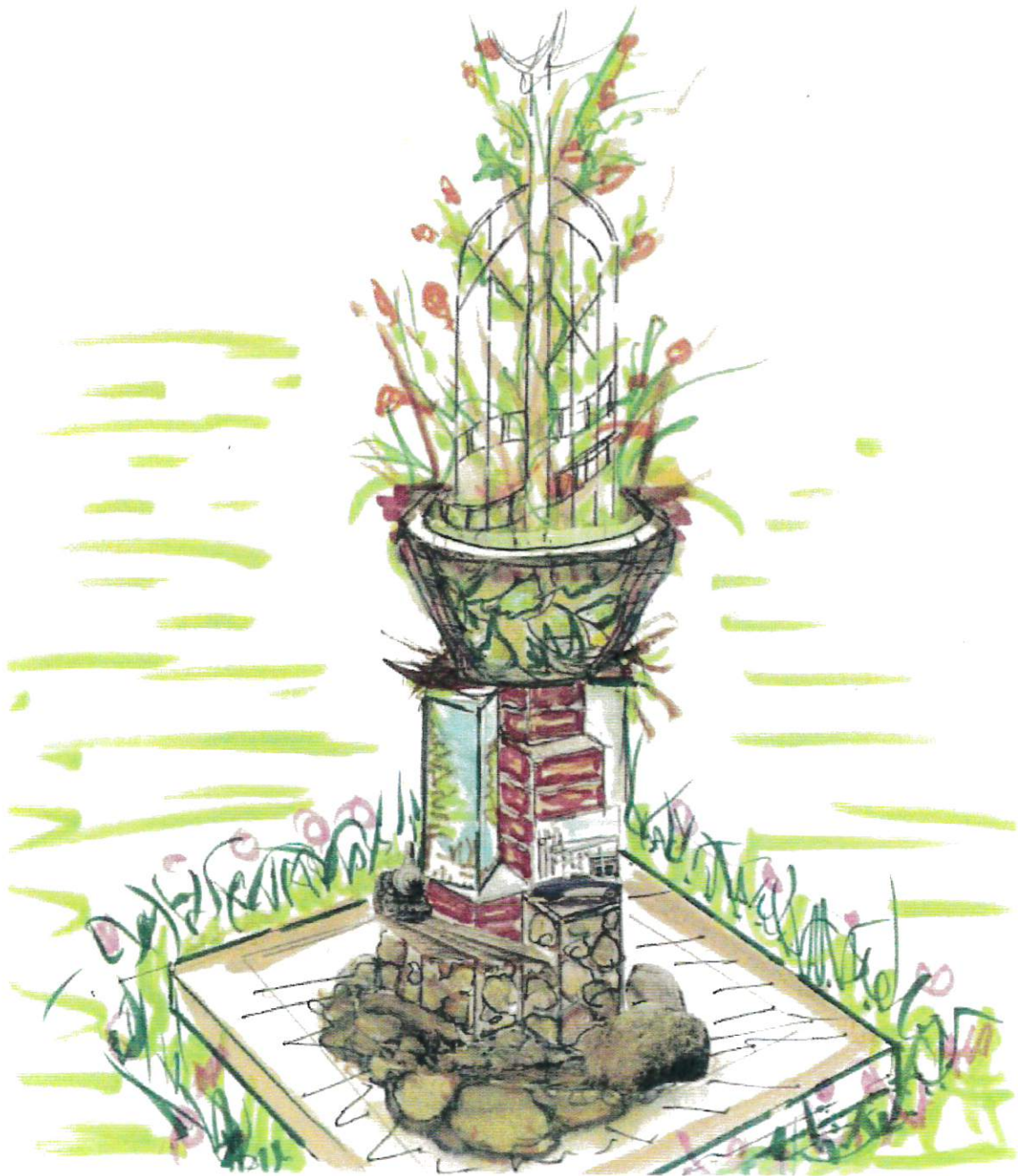

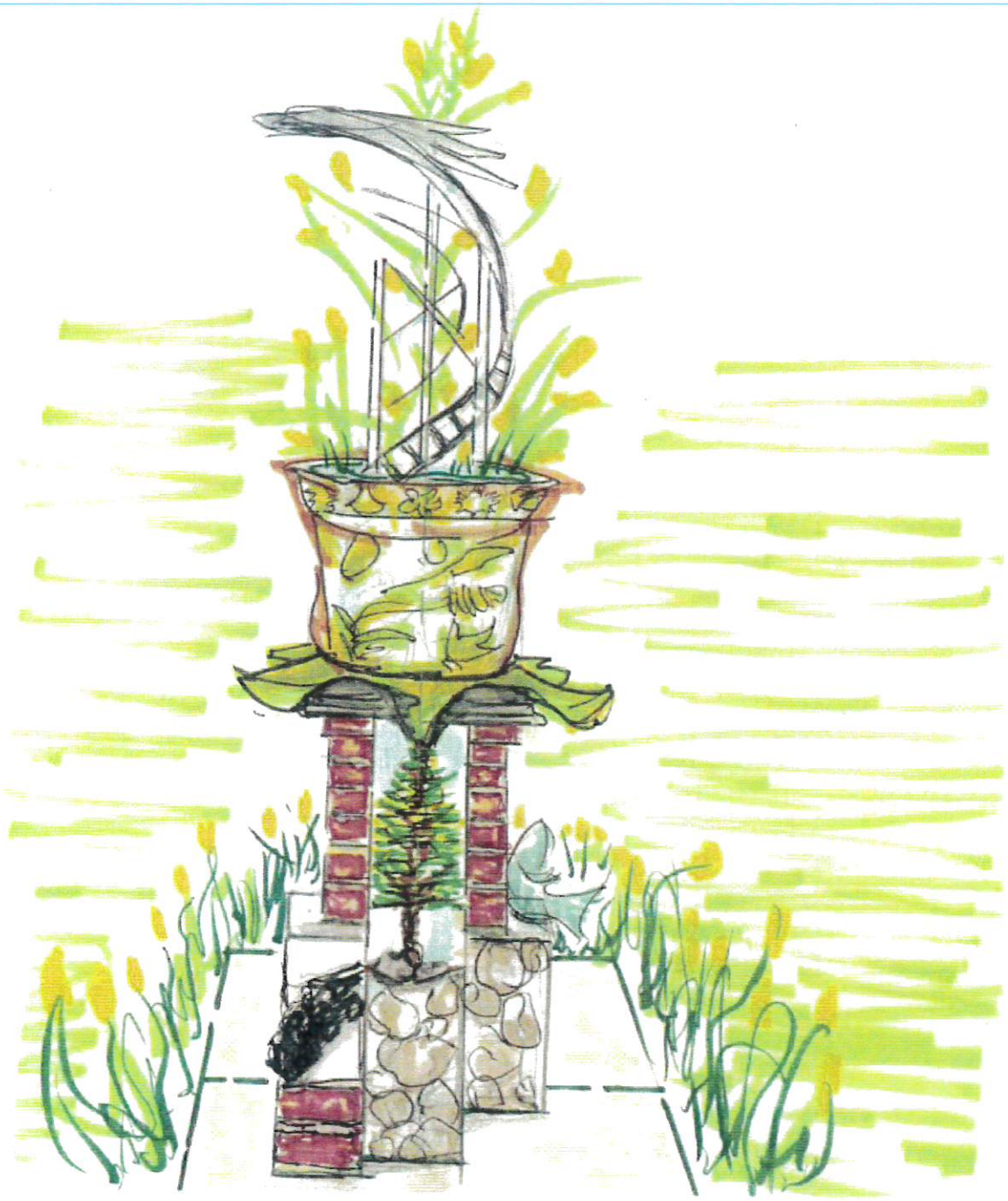

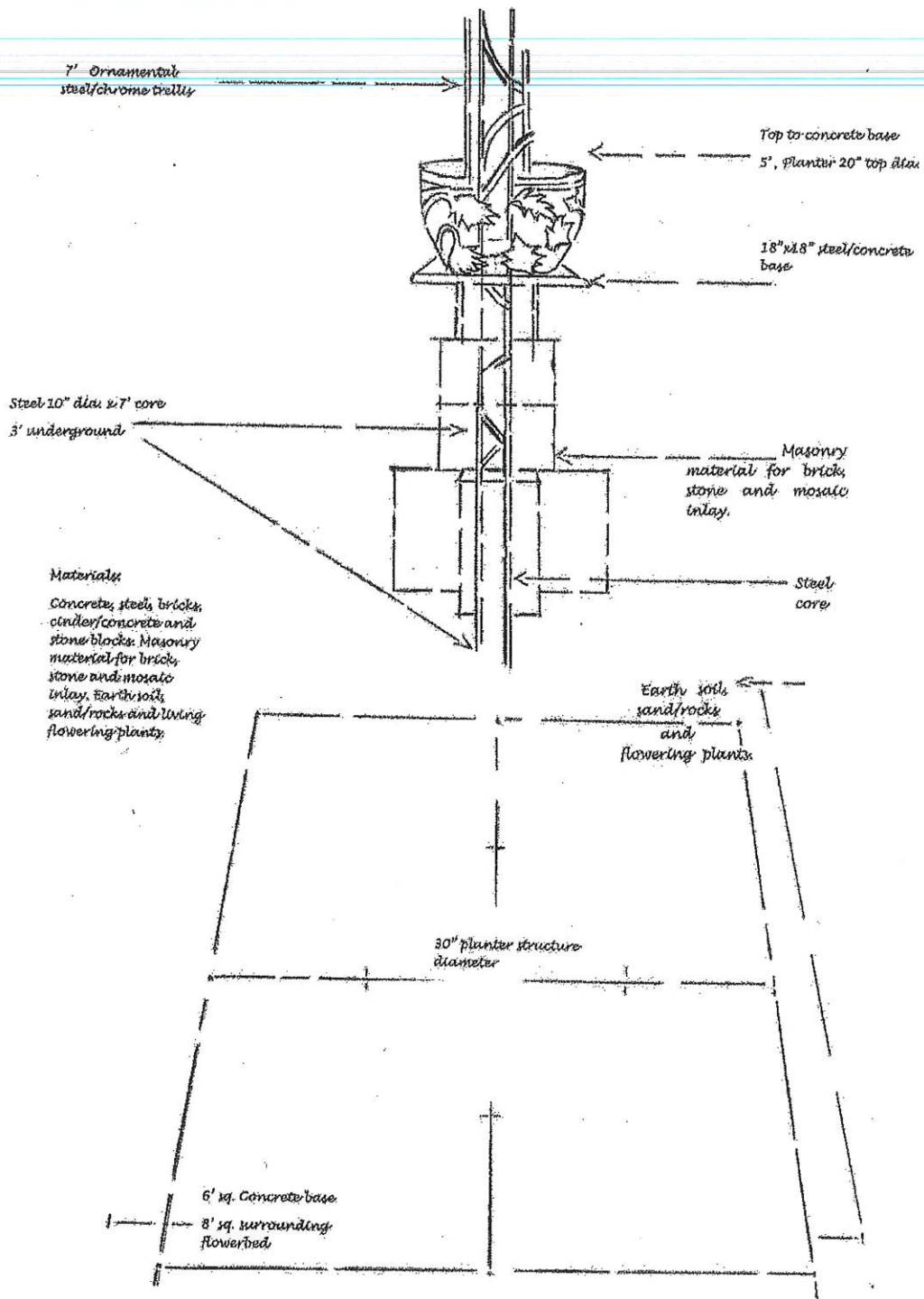

CITY OF PLYMOUTH  
 PROJECT PROPOSAL  
 DETROIT INSTITUTE OF ARTS  
 ARTIST: VITO J. VALDEZ

2019/20

## Photoshopped Version

While actual planter will invariably look different, this Photoshopped version of the marker sketch overlaid on the site location gives a general idea:

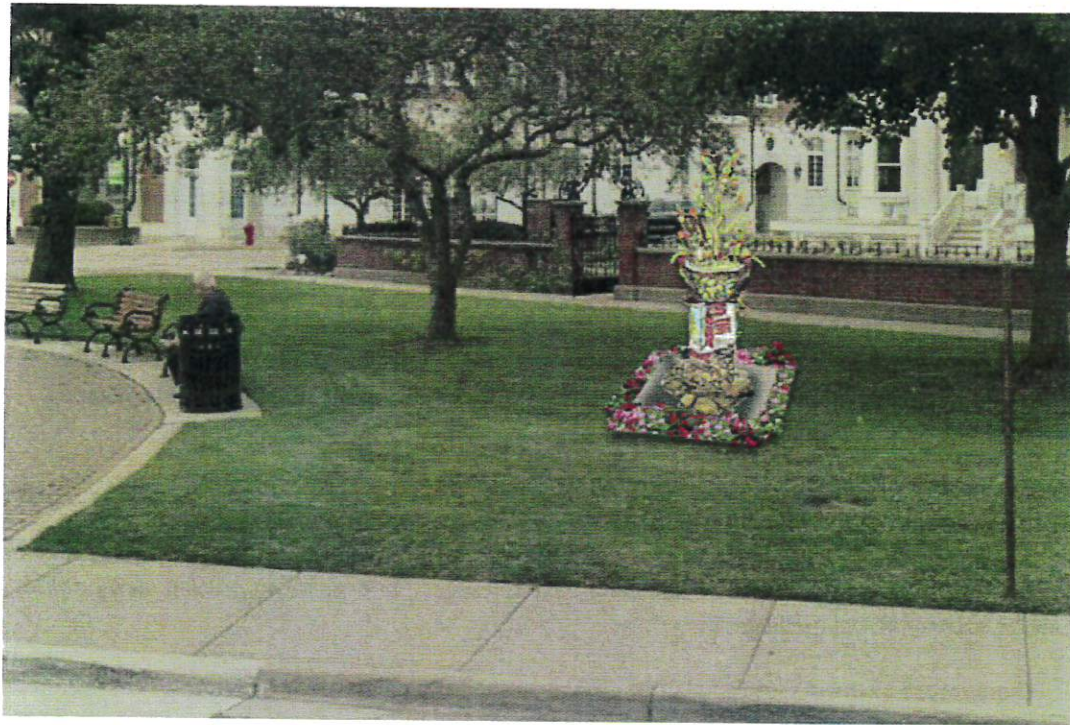

## Dedication Sign

The work will have a dedication sign that will include the City of Plymouth logo and the Detroit Institute of Arts logo, and will read similar to the following:

TITLE

ARTIST

SEASON AND YEAR

This sculpture is a collaboration between the Detroit Institute of Arts and the City of Plymouth through the Partners in Public Art program. It was made possible by generous voter investment in the tri-county millage for the purpose of enriching the quality of life in Wayne County.

In Grateful Appreciation to:

(project stakeholders)

## Timeline

The creation process will take 8-10 weeks at an offsite location, and installation can occur when the weather breaks in Spring, 2020.

## Community Involvement

Beyond the surveys, community members will be invited to create clay tiles at the Plymouth Community Arts Council which will be installed on the sculptural planter.

## City of Plymouth General Rules and Regulations

*GENRULES9 - 10/19/93 - Page 9-1*

*SECTION 9*

*ESTABLISHMENT OF CITY MEMORIALS AND MONUMENTS*

*9.2 TYPES OF MEMORIALS AND MONUMENTS.*

*e. A major one-of-a-kind item, or a major financial portion of the cost of a one-of-a-kind item, which is proposed to be donated by an individual or an organization, and which would carry a plaque or other means of identification acknowledging such donation.*

This sculptural planter is a one-of-a-kind item which will incorporate a plaque acknowledging the partnership between the City of Plymouth and the Detroit Institute of Arts. This project is funded by the tri-county millage for the purpose of enhancing the quality of life in Wayne County.

*9.5 CONTENTS OF A PROPOSAL FOR A MEMORIAL OR MONUMENT.*

*The written proposal for establishing a memorial or monument shall include the following:*

*a. A statement presenting the justification for the proposed memorial or monument. This would include a description of the historic event, or the contributions of the person or organization being memorialized, along with supporting documentation.*

The purpose of this sculptural planter is to represent and celebrate the Plymouth community in a unique, artistic way. As this is a work of public art and not specifically a monument, its purpose

may not fall directly in line with section 9.5, the aspirations and purpose of this project are about the Plymouth community, for the Plymouth community.

*b. A statement about the proposal's compliance with Sections 9.2, 9.3 and 9.4 of this policy.*

The work of public art is a one-of-a-kind item (9.2) of historical proposed by the Detroit Institute of Arts (9.4) that incorporates materials of historical significance (9.3) to the heritage of Plymouth, including Daisy Factory bricks, a Plymouth automobile hood ornament, train references, and community-made leaf tile pieces made with leaves from residents' own trees.

*c. A description of the proposed memorial or monument, including a site plan showing the placement of the proposed memorial or monument in relation to existing and proposed streets, sidewalks, landscaping, utilities, and other nearby monuments and other objects, as appropriate; the design of the proposed memorial or monument, including any words, pictures or other symbols proposed to be on it; and the property owners adjacent to the proposed site.*

See "Project" section above.

*d. A plan for financing the construction and maintenance of the proposed memorial or monument.*

The construction of the sculpture is funded through the tri-county millage. Maintenance of the sculpture lies within the ambit of the City of Plymouth.



*Clay tiles with leaf imprints will be a part of the sculpture*

## Dedication ceremony

Partners in Public Art collaborations conclude with a dedication ceremony at each project location. These are wonderful, celebratory events for project stakeholders, participants, and local and county officials who often give remarks. Below are images of past dedications:



*DIA Director Salvador Salort-Pons speaking at a dedication ceremony for a community mural in Romeo*



*Project stakeholders and local, county, and state politicians*



*Unveiling in progress*



*A crowd gathers at a dedication ceremony in for a community mural in Clawson*



*DIA Senior Vice President for Public Affairs, Dave Flynn, speaking at the event*



*Project stakeholders from Detroit's Osborn Neighborhood Alliance at their sculpture dedication*



*Clarkston Cultural Arts Council who collaborated with us on a public art project in Clarkston*



*Public art brings communities together*



City of Plymouth Historic District Commission  
201 S. Main Plymouth, MI 48170  
Administrative Review of 381 S. Main  
Case Number H19-11  
Agenda Date: January 9, 2020

Address: 381 S. Main

Commonly Known As: Kellogg Park (Triangle area east of S. Union Formerly Known As Vet's Park)

Year Built: N/A, 1837 Platted

Historical Significance: Open Space/Parks

Proposed Changes: Sculpture Installation

**Sec. 18-654. - Duties and powers.**

(a) It shall be the duty of the historic district commission to review all plans for the construction, addition, alteration, repair, moving, excavation or demolition of structures in the historic district and it shall have the power to pass upon such plans before a permit for such activity can be granted. In reviewing the plans, the commission shall follow the U.S. Secretary of the Interior's standards for rehabilitation and guidelines for rehabilitating historic buildings, as set forth in 36 CFR 67, or their equivalent as approved or established by the state bureau of history of the department of state, and shall also give consideration and significance to:

- (1) The historical or architectural value and significance of the historic resource and its relationship to the historic value of the surrounding area;
- (2) The relationship of the exterior architectural features of such historic resource to the rest of the resources and to the surrounding area;
- (3) The general compatibility of the exterior design, arrangement, texture and materials proposed to be used;
- (4) To any other factor, including aesthetics, which it deems pertinent;
- (5) The proposed major changes to open spaces in a historic district. The HDC shall review plans for major changes to these open spaces, such as the removal of large trees (over 12 inches in diameter as measured four feet above ground) or the making of major contour changes in terrain features. The HDC may use its discretion to decide if proposed changes are major in nature or not.

(b) The HDC shall review and act upon exterior features of a resource, and shall not review and act upon interior arrangements unless interior work will cause visible changes to the exterior of the historic resource. The HDC shall not disapprove applications except in regard to considerations as set forth in subsection (a) of this section.

(c) The HDC may delegate the issuance of certificates of appropriateness for specified minor classes of work to its staff, to the inspector of buildings, or to another delegated authority. The HDC shall provide to such delegated authorities specific written standards for issuing the certificates of appropriateness under this subsection. Such delegated authorities shall come before the next regularly scheduled HDC meeting and the HDC shall review the certificates of appropriateness so issued. These reviews are to serve the purpose of keeping the HDC informed as to what certificates of appropriateness for minor work have been issued since the last HDC meeting. On a quarterly basis, the HDC shall review the certificates of appropriateness, if any, issued by the aforesaid delegated authority to determine whether or not the delegated responsibilities should be continued.

(d) In case of an application for work affecting the appearance of a resource or for the alteration, moving or demolition of a resource which the commission deems so valuable to the city that the loss thereof will adversely affect the public purpose of the city, the historic district commission shall endeavor to work out with the owner an economically feasible plan for preservation of the historic resource.

### **SAMPLE MOTION LANGUAGE**

#### **1. Motion to Approve Application**

I move that the Commission issue a Certificate of Appropriateness for application number \_\_. The Findings of Fact are as follows: (list facts of finding). The work as proposed meets the Secretary of the Interior's Standards for Rehabilitation standard number(s) \_\_ and would give consideration and/or significance to the City of Plymouth Ordinance review criteria number(s) \_\_. Vote "Yes" to approve application. Vote "No" to deny application.

#### **2. Motion to Approve Application with Conditions**

I move that the Commission issue a Certificate of Appropriateness for application number \_\_, provided that the following conditions are met: (list conditions). The Findings of Fact are as follows: (list facts of finding). The work would then meet the Secretary of the Interior's Standards for Rehabilitation, standard number(s) \_\_ and would give consideration and/or significance to the following City of Plymouth Ordinance review criteria number(s) \_\_. Vote "Yes" to approve application with conditions. Vote "No" to deny application with conditions.

#### **3. Motion to Postpone Review**

I move that the Commission Postpone Review of application number \_\_ until the next regular meeting scheduled for \_\_. Vote "Yes" to approve postponing the review. Vote "No" to deny postponing the review.

#### **4. Motion to Deny Application**

I move that the Commission issue a Certificate of Appropriateness for application number \_\_. The Findings of Fact are as follows: (list findings of facts that do not warrant the project's approval). The work as proposed does not meet the Secretary of the Interior's Standards for Rehabilitation, standard number(s) \_\_ and would not give consideration

and/or significance to the following City of Plymouth Ordinance review criteria number(s) \_\_. Vote "No" to deny the application. Vote "Yes" to approve the application.

*Note:* Voting "No" to positively framed motion is the easiest way to deny an application's request for a Certificate of Appropriateness. FYI: Making a motion for approval and then voting "No" to deny is the same as making a motion to deny an application and then voting "Yes".

## **5. Motion to Issue a Notice to Proceed**

### **May be used in special conditions or emergencies.**

I move that the Commission issue a Notice to Proceed for application number \_\_. The Findings of Fact are as follows: (list facts of finding). The work as proposed does (not) meet the Secretary of the Interior's Standards for Rehabilitation, standard number(s) \_\_ and would (not) give consideration and/or significance to the following City of Plymouth Ordinance review criteria number(s) \_\_. The work which is approved with this Notice to Proceed is as follows: (list approved work). The work that is not approved/not appropriate requires the following conditions to be met: (list conditions). The proposed work will substantially improve or correct the following: (list notice to proceed options). Additional work desired which is not approved within this Notice to Proceed is to be resubmitted for a Certificate of Appropriateness. Vote "Yes" to approve notice to proceed. Vote "No" to deny notice to proceed.