

ADDENDUM
PAGE 1 OF 1

OWNER:	City of Plymouth 201 Main Street Plymouth, MI 48170
ENGINEER:	Fishbeck 4775 Campus Drive Kalamazoo, MI 49008
DRAWING REVISION NO.:	A1
ISSUED HEREWITH:	
SHEETS:	SR103
ADDITIONAL DOCUMENTS:	Pre-Bid Meeting Minutes
BIDS DUE:	August 25, 2022, 10:00 a.m. (ET)
This Addendum is issued to all Bid Set Holders, is a part of the Contract Documents, and modifies the previously issued Bidding Documents. Acknowledge receipt of this Addendum in the space provided on the Bid form; failure to do so may result in rejection of the Bid.	

ITEM NO. 1:

Sheet: G003 – General Notes (not reissued)

- A. 7.2 Traffic-Bearing Membrane (Deck Coating):
 - 1. Delete Paragraph A and substitute the following:
“A. Install deck coating (full system) at repairs where there is existing deck coating, including concrete, sealant, and floor drain repairs.”

ITEM NO. 2:

Sheet: SR103 – East Stair Existing Conditions (reissued)

- A. Delete Sheet SR103 and substitute with attached Sheet SR103 – Addendum 1 dated 08/12/2022
 - 1. Revisions: Detail 1/SR103 – Dimensions of existing pedestrian bridge updated.

ITEM NO. 3:

Pre-Bid Meeting Minutes (issued)

- A. Refer to attached Pre-Bid Meeting Minutes for discussions and attendance record.

END OF ADDENDUM

Meeting Minutes

PROJECT:	City of Plymouth Central Parking Structure Restoration 2022	DATE:	August 9, 2022
SUBJECT:	Pre-Bid Conference	START:	10:00 a.m.
MEETING SITE:	Plymouth DDA Office	DISTRIBUTED:	August 12, 2022
PREPARED BY:	Justin Thomson, P.Eng.	PROJECT NO.:	220597
ATTENDING:	City of Plymouth – John Buzuvis, Sam Plymale Public – Mike Brace Pullman SST – Zach Carroll RAM Construction – Chris Revis Smith’s Waterproofing – Kelly Dallo Fishbeck – Justin Thomson	Attachments <input checked="" type="checkbox"/> Yes <input type="checkbox"/> No Individuals in the distribution list will receive all attachments unless noted otherwise.	
DISTRIBUTION:	Attendees		

If information contained herein is thought to be inaccurate or incorrect, please contact writer at once for resolution.

Bidding Notes

- Pre-Bid:
 - Prospective Bidders are required to attend and participate in the conference.
 - Refer to the attached Attendance Sheet.
- Bids Due:
 - Thursday, August 25, 2022 @ 10:00 a.m. (ET)
 - Sealed bids will be received at Plymouth City Clerk’s Office.
 - Plymouth City Hall, 201 Main Street, Plymouth, Michigan 48170
- Questions:
 - Deadline: Monday, August 22, 2022 @ 2:00 p.m. (ET)
 - Email directly to Justin Thomson at jthomson@fishbeck.com.
- Bid Bond in the amount of at least 5%.
- The Owner reserves the right to waive any irregularities and to reject any and all Bids. The Owner also reserves the right to delete any item or portion of the work.
- A Performance Bond, a separate Labor and Material Payment Bond, and Insurance in a form acceptable to Owner will be required of the successful Bidder.

Project Scope

1. Reviewed drawings and scope of work, including:
 - a. Majority of the work is related to the replacement of the east stair and structural support of the pedestrian bridge.
 - b. Miscellaneous concrete and sealant repairs at the pedestrian bridge.
 - c. Floor drain replacements at the upper level of the parking structure.
2. Project pricing is lump sum with unit price adjustments.
3. Contractor is responsible for obtaining all permits necessary to complete the work.
 - a. No cost for permits. 5 to 8 business days to process.
4. Contractor is responsible for providing appropriate shoring.
5. Stairway design shall be performed by the supplier. Refer to Specification Section 05 50 00.

Project Phases & Schedule

1. Anticipated Award Date: September 13, 2022 (*subject to DDA approval*)
2. Earliest Mobilization date is September 14, 2022 (*following Fall Festival*).
3. Completion date of concrete and waterproofing work is October 28, 2022.
4. Substantial completion date of Project is December 2, 2022.
 - a. Material lead time for metal fabrication will be considered.
5. Liquidated damages of \$1,000 per day.
6. Construction hours are 7:00 a.m. to 8:00 p.m., 7-days a week.

Construction Phasing

1. Traffic flow shall be maintained to all levels of the structure, including Fleet Street.
 - a. Short term closures (1 to 2 weeks) of the pedestrian bridge and/or Fleet Street may be accommodated with advance notice.
2. Protect pedestrian traffic throughout and around perimeter of parking structure.
3. Contractor shall provide a phasing plan prior to start of construction.
4. Contractor shall only close areas where work is currently being performed.
5. Contractor shall provide a weekly work schedule prior to performing work for the upcoming week.
6. Refer to Drawing G002 for complete Phasing Notes.
7. Staging/laydown area available below vehicular ramp.
8. Employee parking shall be within the work area.

Testing

1. Special inspections at the owners' expense, including steel, concrete, and soils.

Closeout Documents

1. Record drawings and warranties are required at the end of construction.
2. Refer to Specification Section 01 77 00 for complete Closeout Procedures.

Walkthrough

1. A walkthrough was performed following the pre-bid conference.
2. Additional site visits do not need to be coordinated with DDA or Fishbeck.

Questions

1. What is the traffic coating work?
Install deck coating (full system) at repairs where there is existing deck coating, including concrete, sealant, and floor drain repairs. The supported slab and pedestrian bridge have an existing deck coating.
2. Are floor drains to be hot dipped galvanized?
Yes, provide heavy duty galvanized 12-inch diameter floor drains with sediment buckets and heel-proof, vehicular grate.
3. What is the shoring design load?
Design service (unfactored) load of the temporary support at the new column location is 46,000 pounds.

Attendance Sheet



MEETING: Pre-Bid Conference

DATE: August 9, 2022

TIME: 10:00 AM (local time)

PROJECT NAME: Central Parking Structure Restoration 2022

LOCATION: City of Plymouth Downtown Development Authority
831 Penniman Avenue, Plymouth, Michigan 48170

PROJECT NO.: 220597

NAME	COMPANY	PHONE NO.	EMAIL
Sam Plymale	Plymouth DDA	734-455-1453	splymale@plymouthmi.gov
Justin Thomson	Fishbeck	269-365-4770	jthomson@fishbeck.com
Kelly Dalto	Smith's Waterproofing	248-464-3263	Kelly@swcdllc.com
Chris Revis	RAM Construction	734-260-7932	crevis@ramservices.com
John Bozovis	City of Plymouth	734-453-1234	jbozovis@plymouthmi.gov
Zach Carroll	Pullman SST	734-752-9266	zcarroll@pullman-services.com
Mike Brace	Roof Advisor	734-560-6642	



3 BRIDGE CONNECTION - EXISTING CONDITION
SCALE: 1/2" = 1'-0"

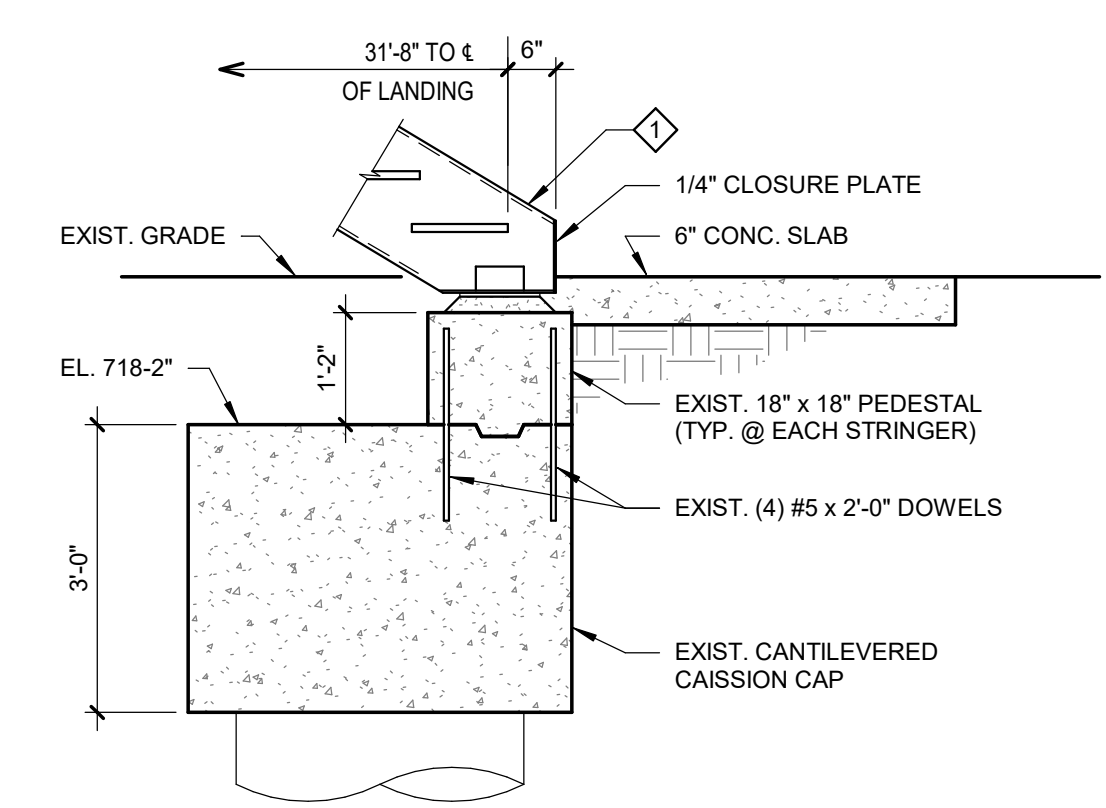

2 SECTION - EXISTING CONDITION
SCALE: 1/2" = 1'-0"

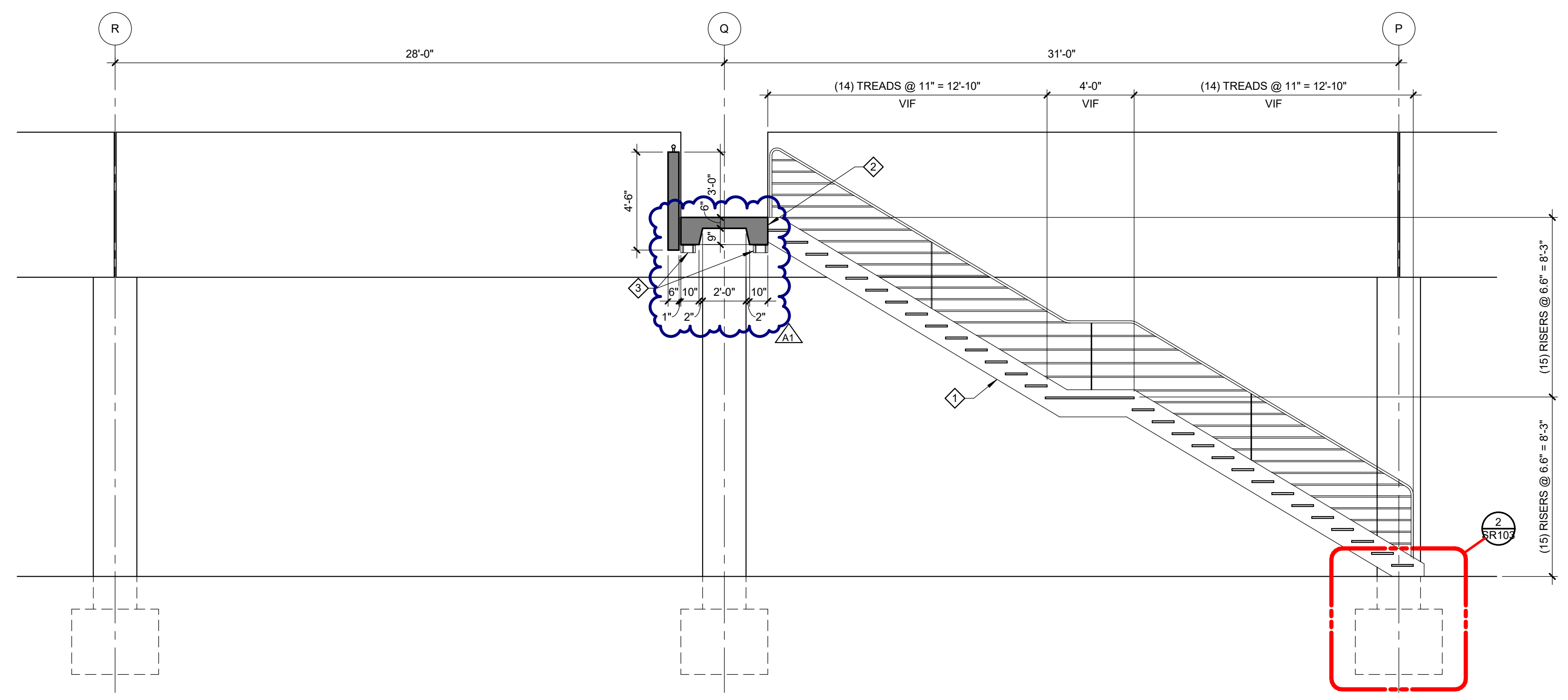

1 EAST STAIR ELEVATION - EXISTING CONDITION
SCALE: 1/4" = 1'-0"

SHEET NOTES

- REFER TO G002 FOR GENERAL NOTES.
- SUPPORTED SLAB AND PEDESTRIAN BRIDGE HAVE AN EXISTING DECK COATING, EXCEPT AT VEHICULAR RAMP.
- ALL COLUMNS AND WALLS HAVE AN EXISTING ELASTOMERIC COATING AT THE INTERIOR OF LEVEL 2, INCLUDING THE PEDESTRIAN BRIDGE.
- PROTECT EXISTING EXPANSION JOINT (WINGED SEAL) BETWEEN THE PEDESTRIAN BRIDGE AND PARKING STRUCTURE. REPAIR TO MATCH EXISTING IF DAMAGED.

KEY NOTES

- DEMOLISH EXISTING STEEL STAIR, STRINGERS, RAILING, TREADS, AND CONNECTIONS.
- REMOVE EXISTING ANGLE AND FACE PLATE. PERFORM BEAM REPAIR, REFER TO DETAIL 6/SR501.
- DEMOLISH EXIST BEARING ANGLES, CLEAN AND PAINT EXISTING EMBED PLATES TO REMAIN.
- CLEAN EXISTING CONCRETE MEMBERS WHICH HAVE BEEN STAINED BY PREVIOUS LEAKING OR LEACHING. REFER TO SECTION 02 41 23.
- RELOCATE EXISTING LIGHT FIXTURE FROM COLUMN TO FACE OF SPANDREL. CONDUIT TO MATCH EXISTING.

REVISIONS	
08/12/2022	A1 ADDENDUM #1

7/22/2022 BIDDING & CONSTRUCTION

Drawn By DEB
Designer FGE
Reviewer JBT
Manager JBT

Hard copy is intended to be 24"x36" when plotted. Scale(s) indicated and graphic quality may not be accurate for any other size.

PROJECT NO.
220597
SHEET NO.

SR103